





UNE ENTREPRISE FAMILIALE 100% FRANÇAISE

Il y a plus de trente ans, Éric Baron reprenait le flambeau de l'entreprise familiale CVL, fondée par son père Henri en 1960. Le nouveau président a très vite impulsé un virage vers le design et un parti pris contemporain. La collection de luminaires traditionnels en fer forgé et céramique a progressivement laissé place à une gamme résolument moderne, aujourd'hui réalisée en laiton massif. La qualité du matériau et la perfection des lignes sont les qualités premières qui inspirent les clients de CVL.

Forte de six décennies d'expérience, son équipe de trente-cinq salariés s'applique au quotidien à préserver et enrichir ces savoir-faire uniques dans la fabrication de luminaires en laiton, au sein d'une unité de production installée près d'Angers, dans la région Pays de la Loire...

Les artisans de CVL sont tous des hommes et femmes de l'art, passionnés par leur métier. Ils fabriquent l'intégralité des collections à la main, dans la maîtrise de gestes minutieux, au sein d'ateliers à la frontière de l'orfèvrerie et de l'industrie.

ESPRIT D'ÉQUIPE ET FAMILLE DE CRÉATEURS

Designer intégrée chez CVL, Émilie Cathelineau est chargée de développer les nouveaux produits et d'animer la cellule de création et le bureau d'études. Elle planche également sur les projets sur mesure: ce service est unanimement apprécié par les prescripteurs dont les requêtes pointues requièrent une expertise poussée. Sans renier son savoir-faire ancestral, CVL a su s'adapter aux nouvelles technologies et s'est dotée de logiciels de création performants, permettant la réalisation de fichiers et rendus 3D indispensables à ses clients.

Depuis plusieurs années, l'entreprise a su s'ouvrir au regard et à l'inventivité de designers indépendants tels que Hervé Langlais, Pauline Deltour, POOL studio ou Sylvain Willenz. Ces fructueuses collaborations sont le gage d'une image de marque modernisée, mais aussi de nouvelles collections, toujours en harmonie avec l'esprit CVL.

A 100% FRENCH FAMILY COMPANY

More than 30 years ago, Éric Baron took over the family business CVL, founded by his father Henri in 1960. The new president very quickly initiated a shift towards design and a contemporary bias. The collection of traditional wrought iron and ceramic lights has gradually given way to a resolutely modern range, now made of solid brass. The quality of the material and the perfection of the lines are the primary qualities that inspire CVL's clients.

With six decades of experience, its team of thirty-five employees works daily to preserve and enrich their unique know-how in the manufacture of brass lighting, within a production unit located near Angers, in the region of the Loire Valley...

CVL artisans are all men and women of art, passionate about their work. They produce all of the collections by hand, mastering meticulous techniques, in workshops on the border line between goldsmith and industry.

TEAM SPIRIT AND FAMILY OF DESIGNERS

Integrated designer at CVL, Émilie Cathelineau is responsible for developing new products and responsible for leading the creation unit and the design office. She also works on bespoke projects: this service is unanimously appreciated by specifiers whose specific requests require in-depth expertise. Without denying its ancestral know-how, CVL has been able to adapt to new technologies and is equipped with high-performance creation software, allowing the creation of 3D files and renderings essential to its customers.

Over the years, the company has opened up to the inventiveness of independent designers such as Hervé Langlais, Pauline Deltour, POOL studio or Sylvain Willenz. These fruitful collaborations are the pledge of a modernized brand image, but also of new collections, always in harmony with the CVL spirit.





UNE DISTRIBUTION INTERNATIONALE ET DES PROJETS À TRAVERS LE MONDE

Forte d'un solide réseau de partenaires, CVL est représentée sur les cinq continents. L'entreprise familiale expose régulièrement ses créations dans les salons les plus prestigieux: Euroluce à Milan, ICFF à New York, Maison et Objet, Architect@Work et Equip'Hotel à Paris... Ses clients, architectes et décorateurs, plébiscitent ses luminaires dans le cadre de leurs projets, résidentiels comme hôteliers. CVL peut s'enorgueillir de sa présence dans des aménagements privés de standing autant que des rénovations hôtelières de prestige et des boutiques de luxe: Waldorf Astoria, Marriott, Four Seasons, Crowne Plaza, Cartier, Boucheron, Harrods... pour n'en citer que quelques-uns.

UN SAVOIR-FAIRE RECONNU ET RECHERCHÉ

Les architectes d'intérieur et décorateurs à la recherche d'un savoir-faire artisanal de haut niveau sont nombreux à confier la réalisation de leurs pièces à CVL. L'entreprise est en permanence à l'écoute de ses clients et de leurs besoins. Elle a développé un regard pointu, tourné vers l'architecture, sans compromis ni concession sur la technicité et la performance. La maîtrise de toutes les étapes de production – dès le prototypage réalisé en interne – et des technologies de l'éclairage, permettent à CVL d'offrir flexibilité et rapidité d'exécution, deux vertus indispensables pour ses clients. Depuis de nombreuses années, CVL travaille également en partenariat avec des maisons d'éditions en France comme à l'étranger, qui lui confient le développement et la fabrication de leurs gammes de luminaires. Que ce soit pour des pièces uniques ou des séries, cette PME est constamment en phase d'auto-évaluation. Elle s'adapte en permanence aux avancées des technologies LED et crée des luminaires sophistiqués qui répondent aux normes internationales de plus en plus strictes. La certification «UL» des produits pour le marché nord-américain, et le développement d'une collection destinée à la salle de bain sont de parfaites illustrations de cette philosophie d'amélioration constante. Pour une qualité irréprochable, chaque produit est vérifié et testé avant emballage.

INTERNATIONAL DISTRIBUTION AND PROJECTS AROUND THE WORLD

With a strong network of partners, CVL is represented on all five continents. The family business regularly exhibits its creations at the most prestigious fairs: Euroluce in Milan, ICFF in New York, Maison et Objet, Architect@Work and Equip'Hotel in Paris... CVL's clients, architects and decorators, select its lighting as part of their projects, both residential and commercial. CVL can be proud of its presence in luxury private facilities as well as prestigious hotel renovations and luxury boutiques: Waldorf Astoria, Marriott, Four Seasons, Crowne Plaza, Cartier, Boucheron, Harrods... to only quote a few.

A RECOGNIZED AND SOUGHT-AFTER KNOW-HOW

Many interior architects and decorators looking for high-level craftsmanship entrust the creation of their pieces to CVL. The company is constantly attentive to its customers and their needs. It has developed a sharp eye for architecture, with no compromises or concessions on technical performance. The control of all stages of production, from prototyping carried out internally and lighting technologies, allow CVL to offer flexibility and speed of execution, two essential virtues for its customers. For many years, CVL has also worked in partnership with publishing houses in France and abroad, who entrust the company with the development and manufacture of their lighting ranges. One-offs or series, this SMB is always questioning itself, constantly adapting, for example, to the evolution of LED technologies and developing complex luminaires that meet ever more demanding international standards. The "UL" certification of products for the North American market, and the development of a bathroom collection, are perfect illustrations of this philosophy of constant improvement. For impeccable quality, each product is checked and tested before packaging.



LA RECONNAISSANCE EPV

CVL Luminaires est fière de faire désormais partie des rares entreprises labellisées Entreprise du Patrimoine Vivant (EPV), récompense remise par le préfet de la région en décembre 2023. Ce label distingue des entreprises qui détiennent un savoir-faire artisanal ou industriel exceptionnel, contribuant ainsi à la richesse du patrimoine économique français. Les entreprises labellisées EPV sont sélectionnées pour leur excellence, leur tradition et leur capacité à innover dans leur domaine.

Le processus d'obtention du label EPV est rigoureux. Les entreprises candidates sont évaluées selon plusieurs critères, tels que la maîtrise des techniques traditionnelles, la qualité de la production, l'ancienneté du savoir-faire, ainsi que leur engagement en matière de Responsabilité Sociétale des Entreprises (RSE). Seules celles qui répondent à des normes élevées et qui incarnent véritablement l'excellence dans leur secteur peuvent prétendre à cette distinction.

Le label EPV est une marque de qualité et de reconnaissance qui offre une visibilité significative aux entreprises qui en bénéficient. Il témoigne non seulement de l'authenticité et de la valeur du patrimoine économique français, mais il contribue également à promouvoir l'innovation et la pérennité des savoir-faire traditionnels.

Ainsi, lorsqu'une entreprise arbore le label EPV, cela signifie qu'elle incarne l'excellence, la tradition, l'innovation et s'engage activement dans des pratiques responsables, faisant d'elle une ambassadrice remarquable du patrimoine vivant français.



EPV RECOGNITION

CVL Luminaires is proud to be one of only a handful of companies to have been awarded the Entreprise du Patrimoine Vivant (EPV) label, an award presented by the regional prefect in December 2023. This certification label distinguishes companies with exceptional craftsmanship or industrial know-how, contributing to the richness of France's economic heritage. EPV-labeled companies are selected for their excellence, tradition and ability to innovate in their field.

The process for obtaining the EPV label is a rigorous one. Candidate companies are evaluated according to a number of criteria, including their mastery of traditional techniques, the quality of their production, the existence of their know-how, and their commitment to Corporate Social Responsibility (CSR). Only those that meet high standards and truly embody excellence in their sector can claim this distinction.

The EPV label is a mark of quality and recognition that offers significant visibility to the companies that benefit from it. Not only does it testify to the authenticity and value of France's economic heritage, it also helps promote innovation and the sustainability of traditional know-how.

So, when a company carries the EPV label, it means that it embodies excellence, tradition and innovation, and is actively committed to responsible practices, making it an outstanding ambassador of France's living heritage.



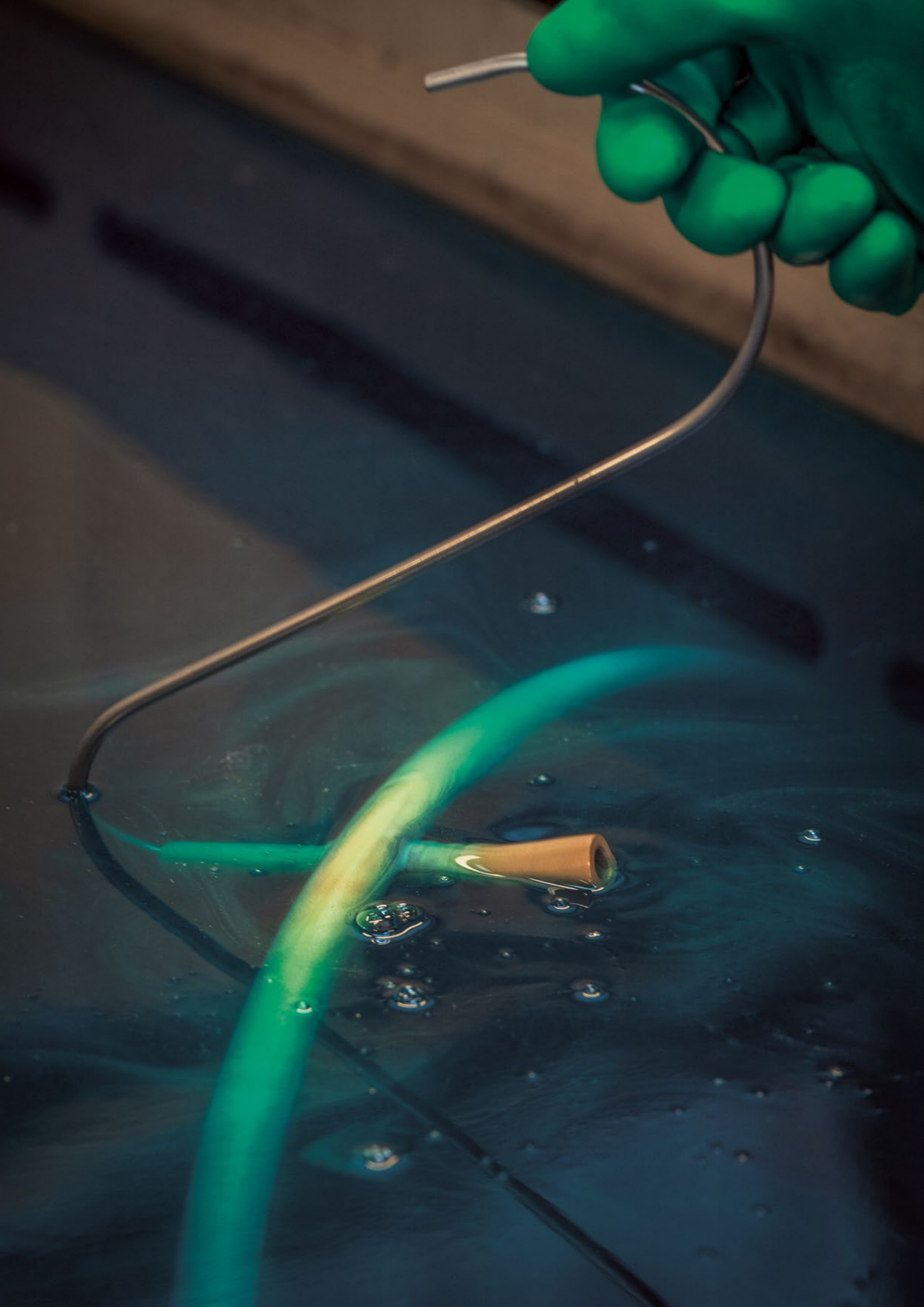

CVL LUMINAIRES : LE FUTUR DURABLE

CVL Luminaires est fière de son engagement envers ses collaborateurs et l'environnement, car elle croit que chaque produit créé devrait éclairer le monde tout en respectant la planète et ses habitants. Voici quelques-unes des actions concrètes que nous menons pour façonner un avenir plus durable :

1. Bien-être des employés

La santé et le bien-être des collaborateurs sont au cœur des préoccupations. Par exemple, CVL veille constamment à la réduction du niveau sonore de ses machines et de ses locaux. Ces derniers, par ailleurs, disposent d'un éclairage naturel : confort acoustique et lumineux créent un environnement propice au bien-être de chacun.

2. Protection de la santé

L'entreprise accorde une importance capitale à la santé de ses salariés, en mettant en place des mesures exigeantes pour assurer un environnement de travail sûr et sain. Par exemple, des systèmes de ventilation ont été spécialement étudiés afin de capter les émissions de poussière et de particules à la source et les retraiter.

3. Formation et emploi

En partenariat avec Pôle Emploi et des organismes de formation, CVL offre des formations diplômantes en interne à ses nouveaux collaborateurs. Cette initiative vise à favoriser l'insertion professionnelle tout en renforçant les compétences des équipes.

4. Recyclage de l'eau

Soucieuse de la protection de l'environnement, CVL a adopté un fonctionnement en rejet zéro pour les eaux utilisées dans le processus de production. L'eau est maintenue en circuit fermé dans l'usine où elle est recyclée puis réutilisée en continu.

5. Contrôles environnementaux

L'entreprise effectue également régulièrement des contrôles et des analyses approfondis sur ses rejets atmosphériques, s'assurant ainsi d'être très en deçà des normes environnementales les plus strictes.

6. Zéro perte

La récupération des chutes de matières premières fait partie intégrante du processus de fabrication. Ainsi, les déchets sont minimisés et recyclés.

7. Emballages durables

Dans une démarche de réduction de son empreinte environnementale, les emballages en polystyrène et les boîtes plastiques ont été abandonnés à la faveur du papier froissé et du carton recyclé.

CVL LUMINAIRES: A SUSTAINABLE FUTURE

CVL Luminaires is proud of its commitment towards its employees and the environment, believing that every product it creates should light up the world while respecting the planet and its inhabitants. Here are some of the concrete actions we carry out to build a more sustainable future:

1. Employee well-being

The health and well-being of our employees is a core concern. For example, CVL constantly strives to reduce the noise level of its machines and premises. In addition, the latter also have natural lighting: acoustic and lighting comfort create an environment that favors everyone's well-being.

2. Health protection

The company attaches the utmost importance to the health of its employees, implementing stringent measures to ensure a safe and healthy working environment. For example, ventilation systems have been specially designed to capture dust and particle emissions at source and reprocess them.

3. Training & employment

In partnership with Pôle Emploi and training organizations, CVL offers its new employees in-house training leading to a diploma. This initiative aims to promote professional integration while strengthening the skills of its teams.

4. Water recycling

To protect the environment, CVL has adopted a zero-discharge operation for water used in the production process. The water is kept in a closed circuit in the factory, where it is recycled and reused continuously.

5. Environmental controls

The company also regularly carries out in-depth checks and analyses on its atmospheric emissions, ensuring that it remains well below the most stringent environmental standards.

6. Zero Waste

The recovery of raw material offcuts is an integral part of the manufacturing process. Thus, waste is minimized and recycled.

7. Sustainable packaging

In an approach to reduce its environmental footprint, polystyrene packaging and plastic boxes have been abandoned in favor of crumpled paper and recycled cardboard.

DESIGNERS



ÉMILIE CATHELINEAU

Lorsqu'Émilie Cathelineau rejoint CVL en tant que designer intégrée en 2003, l'entreprise n'a pas encore de bureau de création. Sa mission : faire évoluer la gamme encore très classique, mais reconnue pour la qualité de ses finitions. Spécialiste du luminaire, elle est la personne de référence pour le développement de produits et fait le lien avec les autres designers. Aujourd'hui, Émilie a plus d'une dizaine de collections à son actif. Déclinées sous toutes les formes de luminaires, elles empruntent leur style autant aux mouvements Art déco qu'au design contemporain.

When Émilie Cathelineau became part of CVL as a designer back in 2003 the company did not yet have a design studio. Her mission was to develop the existing classic range which was known for its quality and various finishes. As an expert in lighting, she is the person in charge for the development of the products and goes over changes and novelties with the other designers. At present, Émilie has designed over ten collections. Made up of all sorts and forms of lights, her collections are inspired from other Art Déco styles to contemporary designs.



PAULINE DELTOUR

Après Olivier de Serres et l'École Nationale Supérieure des Arts Décoratifs de Paris, Pauline Deltour part, durant trois ans, assister à Munich le designer allemand Konstantin Grcic. Elle apprend à ses côtés son métier, envisage de nouvelles méthodes de travail et approfondit son vocabulaire stylistique. En 2011, armée d'une expérience solide, Pauline Deltour revient à Paris et monte son entreprise de design d'objets. Elle collabore également à des projets de scénographie en architecture d'intérieur. En 2017, elle rejoint l'équipe de créateurs de CVL et dessine la collection Signal.

After studying at Olivier de Serres and Paris's famous École nationale supérieure des arts décoratifs, Pauline Deltour assisted the German designer Konstantin Grcic during three years. During her time with him she learnt more about her job, considered new working skills and gained further stylistic vocabulary. In 2011 Pauline Deltour returned to Paris, with even more experience, and set up her own company of designing objects. She also collaborated on interior design projects. In 2017 she joined CVL's designer team and created the Signal collection.



HERVÉ LANGLAIS

Architecte de formation, Hervé Langlais collabore de nombreuses années avec Paul Andreu, spécialiste français des constructions aéroportuaires, et y dessine le Grand Théâtre National de Chine à Pékin ou encore l'Oriental Art Center à Shanghai. Vingt ans plus tard, il retrouve ses premières amours et développe une activité de designer produit. Cet ancien dessinateur de structure accorde une attention particulière aux détails, aux formes épurées et à la rareté des matériaux. Premier designer indépendant à officier pour CVL.

Trained as an architect, Hervé Langlais collaborated for many years with Paul Andreu, a specialist in airport constructions, and together designed the National Centre for the Performing Arts in Beijing in China and even the Shanghai Oriental Art Center. Twenty years later, he started again doing what he loved and developed an activity as a product designer. This former building designer grants specific importance to each detail, refined form and to the rarity of materials. Hervé was the first independent designer to become part of the CVL team.



POOL

Le studio de création parisien, fondé en 2011 par Léa Padovani et Sébastien Kieffer, intervient autant dans les champs du mobilier, de l'environnement que de l'architecture d'intérieur. Collections signées ou collaborations avec d'autres ateliers et manufactures, le duo POOL réfléchit ses créations dans leur contexte global. La composition géométrique, où formes et couleurs agencent des volumes radicaux, se décline comme une véritable marque de fabrique du tandem transdisciplinaire.

The Parisian design studio, founded in 2011 by Léa Padovani and Sébastien Kieffer, intervenes in as much domains as furniture, environment, and interior architecture. The duo POOL studies its creations in a global context, either when signing their own collections or collaborating with other workshops and manufacturers. The geometric composition, in which shapes and colors combine to form radical volumes, is a true trademark of the transdisciplinary tandem.



SYLVAIN WILLENZ

Né à Bruxelles en 1978, Sylvain Willenz a vécu aux Etats-Unis, en Belgique et en Grande Bretagne. Diplômé du Royal College of Art de Londres en 2003, Willenz ouvre un an plus tard son bureau de design à Bruxelles. Willenz fut nommé designer Belge de l'année en 2009. Connu pour son esthétique simple et graphique, Willenz est fasciné par la l'industrie et l'artisanat, la production et les matériaux. Au cours des années, il a développé un style singulier, une ligne claire, insufflant ainsi à ses créations une élégance unique, classique et si reconnaissable aujourd'hui.

Born in Brussels in 1978, Sylvain Willenz has lived consecutively in the US, Belgium and in the UK. Sylvain studied MA Design Products at the Royal College of Art in London, graduating in 2003. In 2004, he opened his Design Office, based in Brussels, Belgium. Willenz was named Belgian Designer of the Year in 2009. Renown for his strong yet simple graphic aesthetic, Sylvain is fascinated by production, manufacturing and pays great attention to detail. Over the years, he has developed a singular style, a "ligne claire", impregnating his creations with a unique and classical elegance that is today so recognizable.



INDEX

A

- 18 **Airy** Appliques – Wall lights
- 22 **Arborescence** Suspensions – Pendants
- 25 **Arborescence** Appliques – Wall lights
- 25 **Arborescence** Lampes de table – Table lamps
- 30 **Arborescence** Lampadaires – Floor lamps
- 32 **Atmos** Appliques – Wall lights

C

- 40 **Calé(e)** Suspensions – Pendants
- 50 **Calé(e)** Appliques – Wall lights
- 51 **Calé(e)** Spots
- 52 **Calé(e)** Lampes de table – Table lamps
- 54 **Calé(e)** Lampadaires – Floor lamps
- 56 **Cercle & trait** Suspensions – Pendants
- 62 **Cercle & trait** Potence – Deported wall lamp
- 63 **Cercle & trait** Liseuse – Standing reading lamp
- 65 **Cercle & trait** Lampadaire – Floor lamp
- 66 **Compass** Suspension – Pendant
- 68 **Compass** Applique – Wall light
- 70 **Constellation** Appliques – Wall lights
- 74 **Cornet** Suspension – Pendant
- 79 **Cornet** Appliques – Wall lights
- 80 **Couture** Lampe de table – Table lamp

E

- 84 **Earth** Appliques – Wall lights
- 92 **Éclipse** Applique – Wall light
- 96 **Extra** Suspensions – Pendants

F

- 103 **Fléa** Suspension – Pendant
- 100 **Fléa** Applique – Wall light

G

- 104 **Gamma** Suspensions – Pendants
- 111 **Gamma** Appliques – Wall lights

J

- 114 **Janed** Appliques – Wall lights
- 120 **Janed** Lampe de table – Table lamp

L

- 128 **Link** Appliques – Wall lights
- 122 **Link** Liseuses – Reading wall lights
- 133 **Link** Lampadaire – Floor lamp
- 133 **Link** Lampe de table – Table lamp
- 134 **Louis** Suspensions – Pendants

N

- 140 **Nacho** Suspensions – Pendants

P

- 144 **Pirouette** Appliques – Wall lights

R

- 148 **Ring** Suspension – Pendant

S

- 152 **Saturne** Suspension – Pendant
- 156 **Signal** Suspensions – Pendants
- 164 **Signal** Appliques – Wall lights
- 159 **Signal** Lampadaires – Floor lamps
- 168 **Solitaire** Lampadaires – Floor lamps
- 172 **Storm** Suspension – Pendant
- 175 **Storm** Applique – Wall light
- 175 **Storm** Lampadaire – Floor lamp
- 174 **Storm** Lampes de table – Table lamps
- 178 **Strate** Appliques – Wall lights

T

- 190 **Tétra** Applique – Wall light

U

- 194 **Upper** Lampadaire – Floor lamp

W

- 202 **Wonder** Applique – Wall light
- 198 **Wonder** Lampes de table – Table lamps

SALLE DE BAIN BATHROOM

- 206 **IP Backstage** Appliques – Wall lights
- 212 **IP Calé(e)** Appliques – Wall lights
- 214 **IP Cornet** Appliques – Wall lights
- 216 **IP Gamma** Appliques – Wall lights
- 218 **IP Janed** Appliques – Wall lights

- 220 **IP Link** Appliques – Wall lights
- 224 **IP Metrop** Appliques – Wall lights
- 228 **IP Signal** Appliques – Wall lights
- 232 **IP Storm** Appliques – Wall lights

- 239 **Finitions / Finishes**

SUSPENSIONS – PENDANT LIGHTS



Arborescence
p. 22

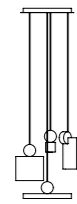

Calé(e)
p. 40

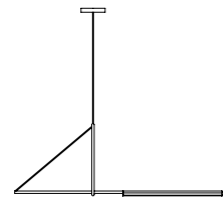

Cercle & trait
p. 56



Compass
p. 66

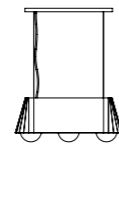

Cornet
p. 74

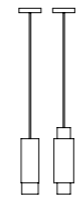

Extra
p. 96



Flea
p. 103

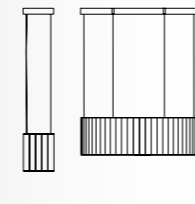

Gamma
p. 104



Louis
p. 134

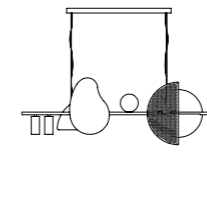

Nacho
p. 140



Ring
p. 148

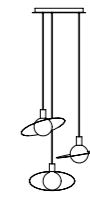

Saturne
p. 152

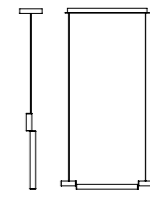

Signal
p. 156

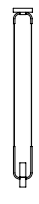

Storm
p. 172

APPLIQUES – WALL LIGHTS

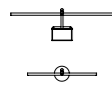

Airy
p. 18

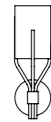

Arborescence
p. 25

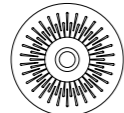

Atmos
p. 32

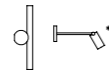

Calé(e)
p. 50

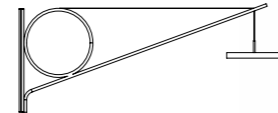

Cercle & trait
p. 62



Compass
p. 68

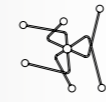

Constellation
p. 70



Earth
p. 84



Cornet
p. 79



Eclipse
p. 92



Flea
p. 100

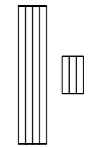

Gamma
p. 111



Janed
p. 114

LAMPES DE TABLE – TABLE LAMPS

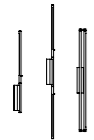

Link
p. 122



Pirouette
p. 144

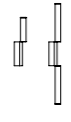

Signal
p. 164



Storm
p. 175

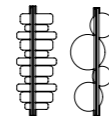

Strate
p. 178



Tétrà
p. 190



Wonder
p. 202



Arborescence
p. 25

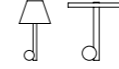

Calé(e)
p. 52



Couture
p. 80



Janed
p. 120



Link
p. 133



Storm
p. 174



Wonder
p. 198

LAMPADAIRES – FLOOR LAMPS

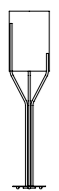

Arborescence
p. 30

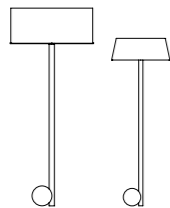

Calé(e)
p. 54

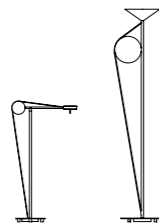

Cercle & trait
p. 65



Link
p. 133

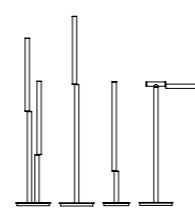

Signal
p. 159



Solitaire
p. 168



Storm
p. 175

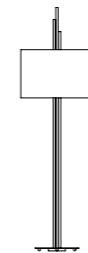

Upper
p. 194

SALLE DE BAIN – BATHROOM



IP Backstage
p. 206



IP Calé(e)
p. 212



IP Cornet
p. 214



IP Gamma
p. 216



IP Janed
p. 218



IP Link
p. 220

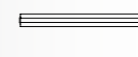

IP Metrop
p. 224

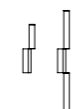

IP Signal
p. 228



IP Storm
p. 232



AIRY

Gamme de réflecteurs tableaux épurés et graphiques, la collection est disponible dans de nombreuses options de longueur et de socles. L'applique *Airy* sait se faire discrète pour une mise en lumière de l'œuvre qu'elle accompagne.



A range of sleek, graphic picture lights, this collection is available in numerous lengths for the reflector and shapes for the base. The *Airy* wall light is discreet enough to highlight the work it is illuminating.

Finitions
Finishes

Détails page 239

● Laiton satiné SB Satin brass	● Graphite satiné SG Satin graphite	● Nickel satiné SN Satin nickel	● Cuivre satiné SC Satin copper
● Laiton poli PB Polished brass	● Graphite poli PG Polished graphite	● Nickel poli PN Polished nickel	● Cuivre poli PC Polished copper

Matériaux
Material

Tous – All Laiton massif Solid Brass	Tous – All Diffuseur polycarbonate satiné Satin Polycarbonate diffuser	Airy Potence Socle aluminium peint noir Black painted aluminum base
--	--	--

Source
Lamping

Airy 214 R/L/P (214 mm – 8.4")	LED intégrée 192lm 2700°K 4W	Alim. électronique 24V intégrée	Variable (phase cut)
	Integrated LED 192lm 2700°K 4W	Int. power supply 24V included	Dimmable (phase cut)
Airy 414 R/L/P (414 mm – 16.3")	LED intégrée 384lm 2700°K 6W	Alim. électronique 24V intégrée	Variable (phase cut)
	Integrated LED 384lm 2700°K 6W	Int. power supply 24V included	Dimmable (phase cut)
Airy 514 R/L/P (514 mm – 20.2")	LED intégrée 480lm 2700°K 8W	Alim. électronique 24V intégrée	Variable (phase cut)
	Integrated LED 480lm 2700°K 8W	Int. power supply 24V included	Dimmable (phase cut)
Airy 614 R/L/P (614 mm – 24.2")	LED intégrée 576lm 2700°K 9W	Alim. électronique 24V intégrée	Variable (phase cut)
	Integrated LED 576lm 2700°K 9W	Int. power supply 24V included	Dimmable (phase cut)
Airy 814 R/L/P (814 mm – 32")	LED intégrée 768lm 2700°K 11W	Alim. électronique 24V intégrée	Variable (phase cut)
	Integrated LED 768lm 2700°K 11W	Int. power supply 24V included	Dimmable (phase cut)
Airy 1014 R/L/P (1014 mm – 39.9")	LED intégrée 960lm 2700°K 13W	Alim. électronique 24V intégrée	Variable (phase cut)
	Integrated LED 960lm 2700°K 13W	Int. power supply 24V included	Dimmable (phase cut)
Airy 1214 L/P (1214 mm – 47.8")	LED intégrée 1152lm 2700°K 15W	Alim. électronique 24V intégrée	Variable (phase cut)
	Integrated LED 1152lm 2700°K 15W	Int. power supply 24V included	Dimmable (phase cut)
Airy 1414 L/P (1414 mm – 55.7")	LED intégrée 1344lm 2700°K 17W	Alim. électronique 24V intégrée	Variable (phase cut)
	Integrated LED 1344lm 2700°K 17W	Int. power supply 24V included	Dimmable (phase cut)
Airy 1614 L/P (1614 mm – 63.5")	LED intégrée 1536lm 2700°K 19W	Alim. électronique 24V intégrée	Variable (phase cut)
	Integrated LED 1536lm 2700°K 19W	Int. power supply 24V included	Dimmable (phase cut)

Designer

Émilie Cathelineau

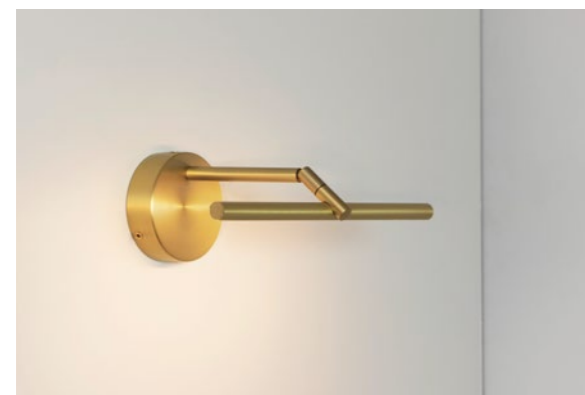

Airy R SB

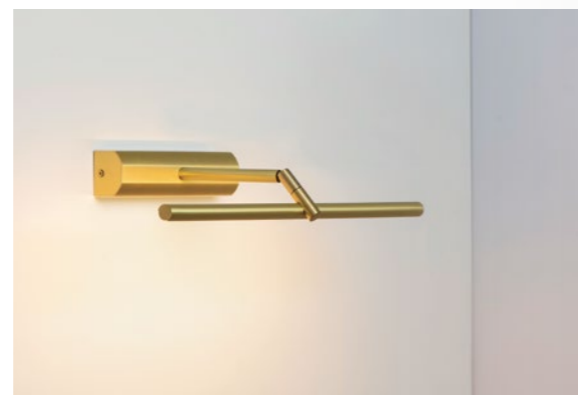

Airy L SB



Airy P SB

Airy R Socle rond – Round base

Uniquement de 214 à 1014 – Only from 214 to 1014

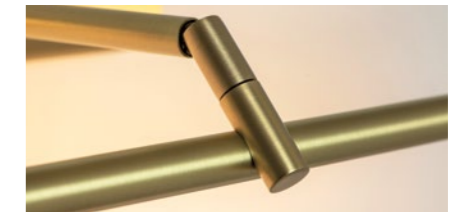
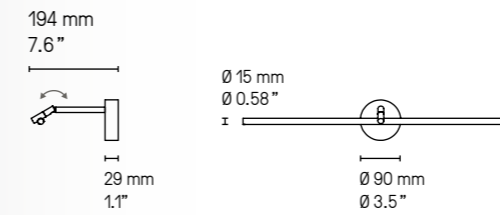

Longueurs – Lengths

214, 414, 514, 614, 814, 1014, 1214, 1414, 1614
Longueurs sur mesure possibles sur demande.
Custom lengths available upon request.

Airy L Socle long – Long base

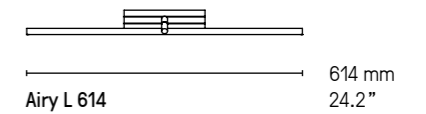
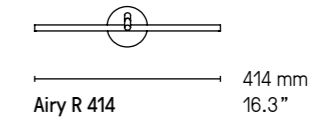
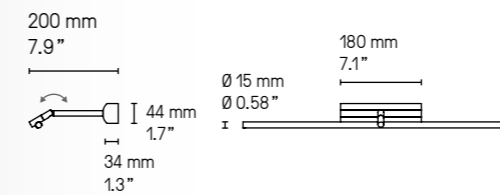

Airy P Socle potence – Stem base

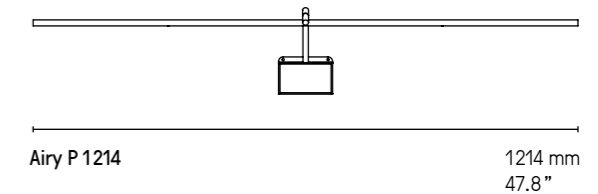
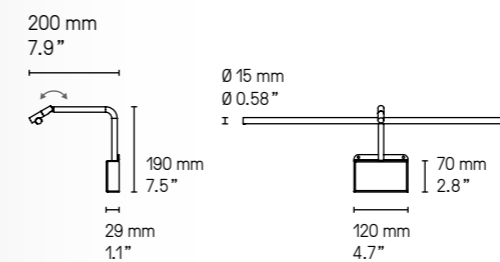



ARBORESCENCE

Collection ouverte, *Arborescence* est une gamme complète qui se décline en différentes dimensions. Évolutive, vous avez la possibilité de vous orienter sur du sur-mesure.



One of our most popular collections, *Arborescence* is a complete range in a variety of sizes and finishes. As a flexible concept, you can customize the light into a bespoke product.

Finitions Finishes	● Laiton satiné SB Satin brass	● Graphite satiné SG Satin graphite	● Nickel satiné SN Satin nickel	● Cuivre satiné SC Satin copper
	● Laiton poli PB Polished brass	● Graphite poli PG Polished graphite	● Nickel poli PN Polished nickel	● Cuivre poli PC Polished copper

Détails page 239

Abat-jour Lampshade	□ Drop Paper® 100	■ Drop Paper® 101
--------------------------------------	-------------------	-------------------

Matériaux Material	Tous – All Laiton massif Solid Brass	Tous – All Abat-jour Drop Paper® M1 Lampshade Drop Paper® M1	Lampes de table – Table lamps Lampadaires – Floor lamps Câble textile noir (longueur ≈ 2 m) Black textile cable (length ≈ 78.7")
-------------------------------------	--	--	---

Source Lamping	Suspensions – Pendants		
	Suspensions – Pendant lights 1 x E27 LED 20W max. non fournie 1 x E27 LED 20W max. not included 1 x E26 type A 150W. Bulb not included		



Variation*
Dimming*

Appliques – Wall lights

Applique – Wall light XL 1 x E27 LED 20W max. non fournie 1 x E27 LED 20W max. not included 1 x E26 type A 100W. Bulb not included		
Applique – Wall light XS 1 x E27 LED 20W max. non fournie 1 x E27 LED 20W max. not included 1 x E26 type A 60W. Bulb not included		

Variation*
Dimming*

Lampe de table – Table lamp

Lampe de table – Table lamp 1 x E27 LED 20W max. non fournie 1 x E27 LED 20W max. not included 1 x E26 type A 100W. Bulb not included		Interrupteur sur câble Cable switch Cable switch
--	--	--

Lampadaires – Floor lamps

Lampadaires – Floor lamps 1 x E27 LED 20W max. non fournie 1 x E27 LED 20W max. not included 1 x E26 type A 150W. Bulb not included		
	Variateur à pied Foot operated dimmer Foot operated switch	Variation* Dimming*

Designer Hervé Langlais

* Les luminaires variables nécessitent l'utilisation d'ampoules compatibles avec la variation.
All dimmable light fixtures require the use of compatible bulbs.

Applique – Wall light XL

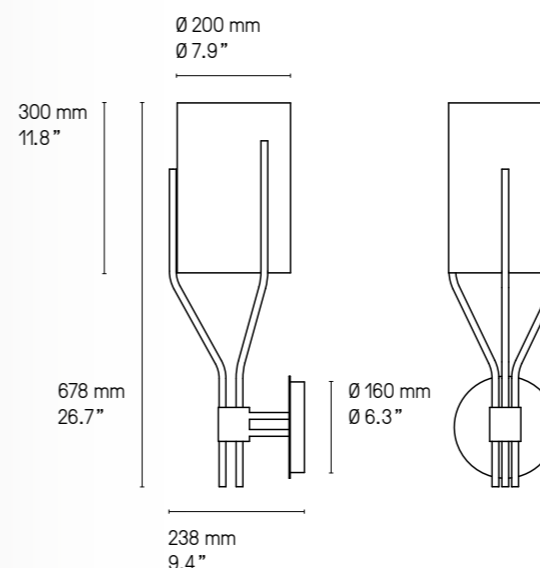

Applique – Wall light XS

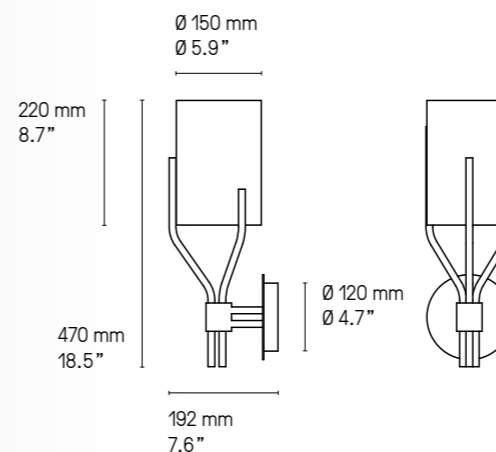

Applique – Wall light Arborescence XS SG

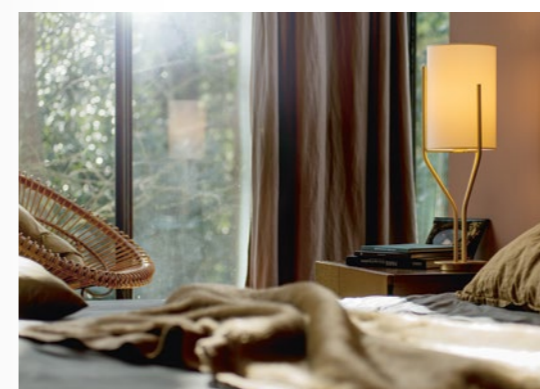

Lampe de table – Table lamp Arborescence SB

Lampe de table – Table lamp

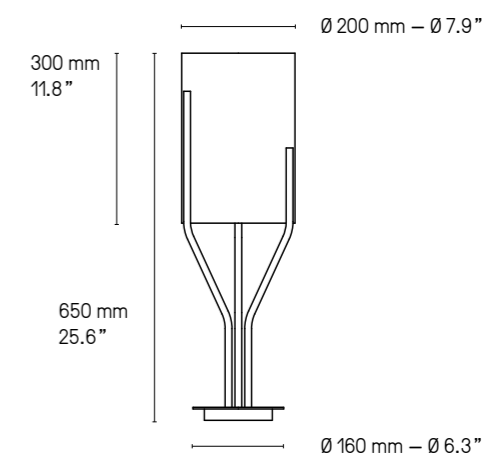

Suspension – Pendant XXS

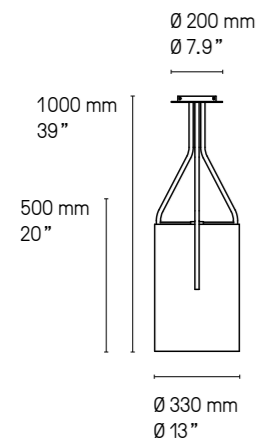

Suspension – Pendant XS

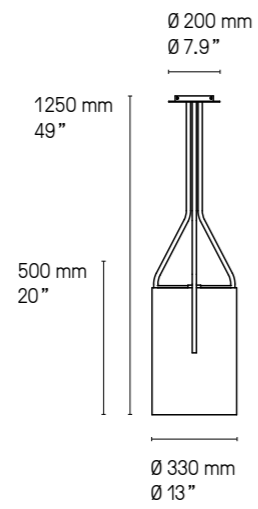

Suspension – Pendant S

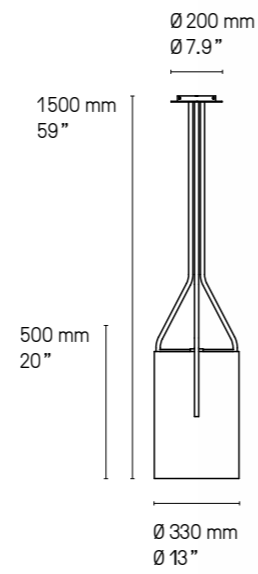

Suspension – Pendant L

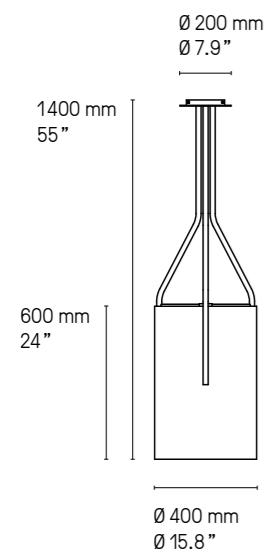

Suspension – Pendant XL

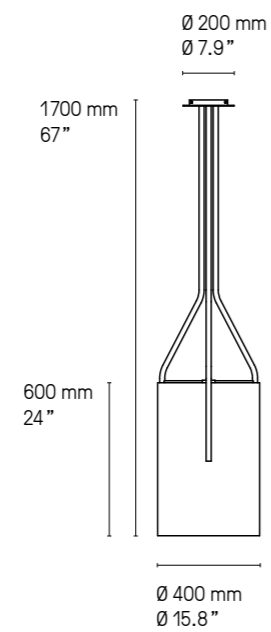

Suspension – Pendant XXL

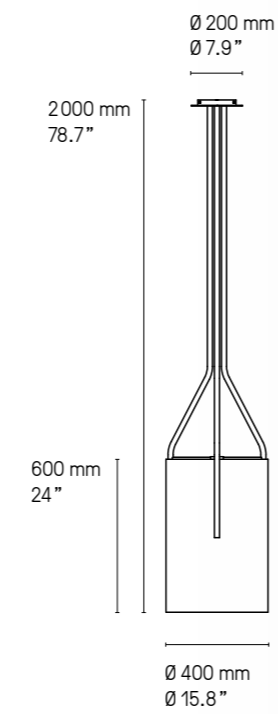

Hauteur sur mesure, version LED et DALI sur demande.
Custom heights, LED and DALI version upon request.



Suspension – Pendant Arborescence XXS + XS + S PB



Lampadaire – Floor lamp **XXS**

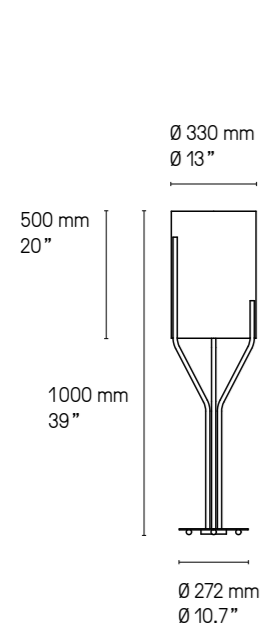

Lampadaire – Floor lamp **XS**

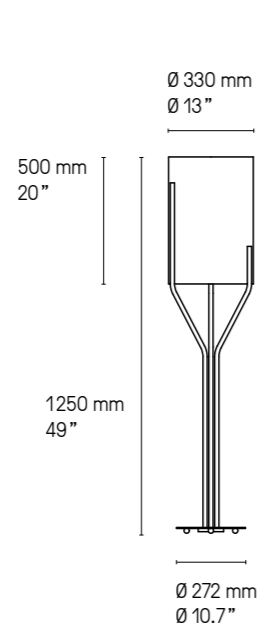

Lampadaire – Floor lamp **S**

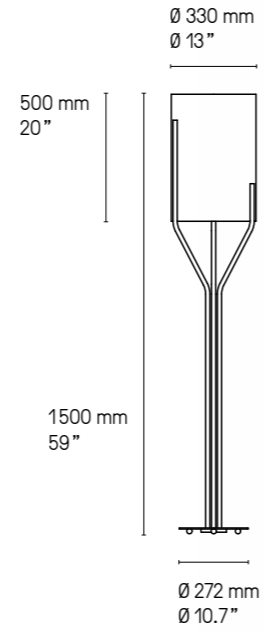

Lampadaire – Floor lamp **L**

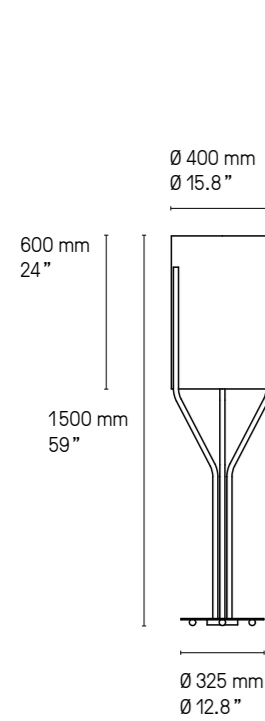

Lampadaire – Floor lamp **XL**

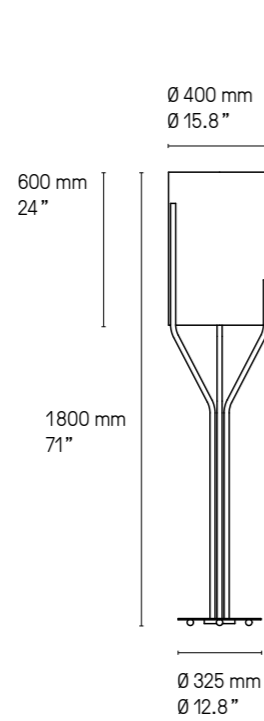

Lampadaire – Floor lamp **XXL**

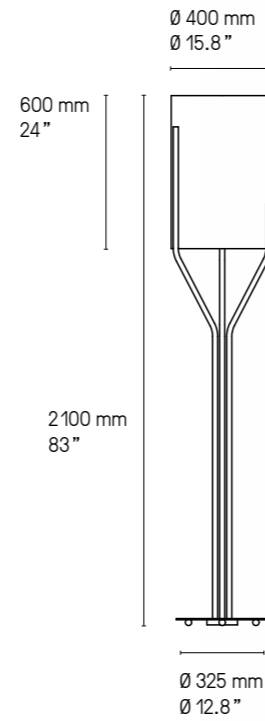

Hauteur sur mesure, version LED et DALI sur demande.
Custom heights, LED and DALI version upon request.



Lampadaire – Floor lamp Arborescence XL + S SG



ATMOS

Au centre de sa grande couronne ajourée, les disques concentriques d'*Atmos* se succèdent jusqu'à son cœur lumineux. Grande sœur de l'applique *Earth*, *Atmos* se distingue par sa grande taille et la multitude de combinaisons de décors possibles.



At the center of its large openwork crown, the concentric discs of *Atmos* follow one another up to its luminous heart. Big sister to the *Earth* wall lamp, *Atmos* is distinguished by its large size and the multitude of possible decor combinations.

Finitions
Finishes ① + ② + ③ + ④

- Laiton satiné
- Graphite satiné
- Nickel satiné
- SB** Satin brass
- SG** Satin graphite
- SN** Satin nickel

Détails page 239

Matériaux
Material Laiton massif
Solid brass

Source
Lamping

LED intégrée	1700 lm	2700° K	22 W	Alim. électronique 24 V intégrée	Variable (phase cut)	
Integrated LED	1700 lm	2700° K	22 W	Integrated 24 V power supply	Dimmable (phase cut)	
Integrated LED	1700 lm	2700° K	25 W	Integrated 24 V power supply	Dimmable (phase cut)	Damp

Designer Émilie Cathelineau

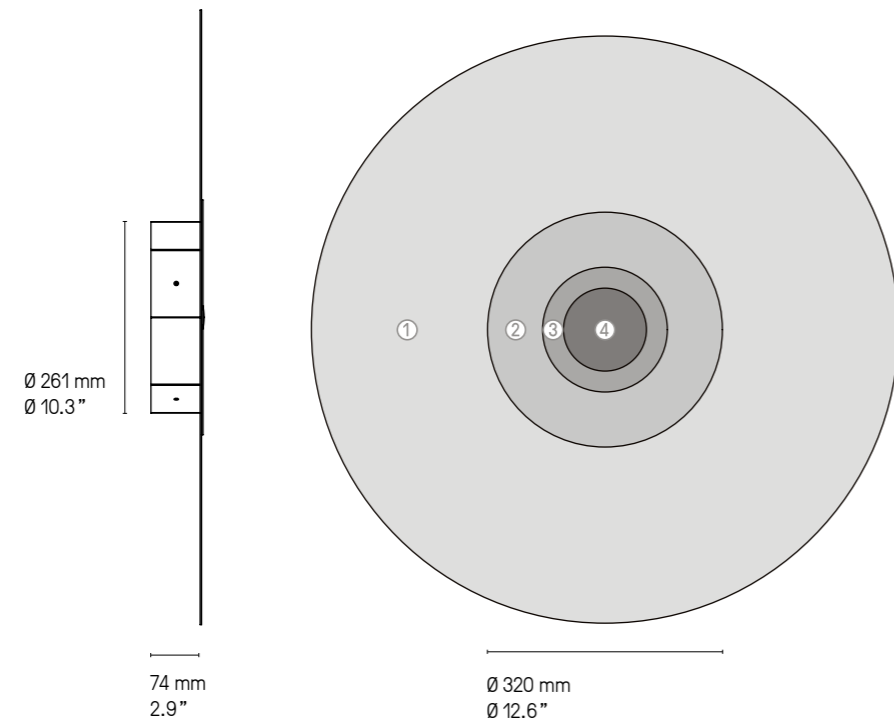

Atmos Lace

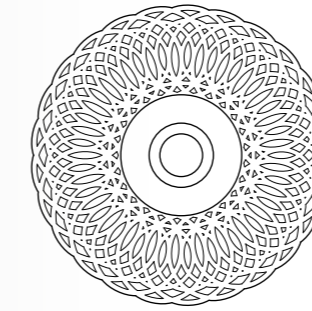

Atmos Lace SB/SB/SG/SB

Atmos Racine

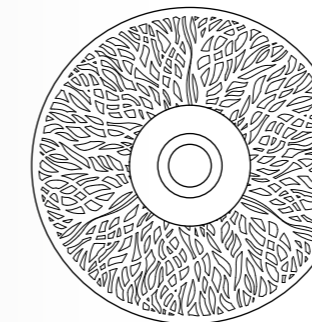

Atmos Racine SB/SG/SG/SB



Atmos Racine SB/SG/SG/SB

Atmos Pop

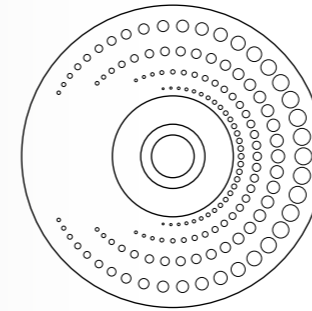

Ø 800 mm
Ø 31.5"

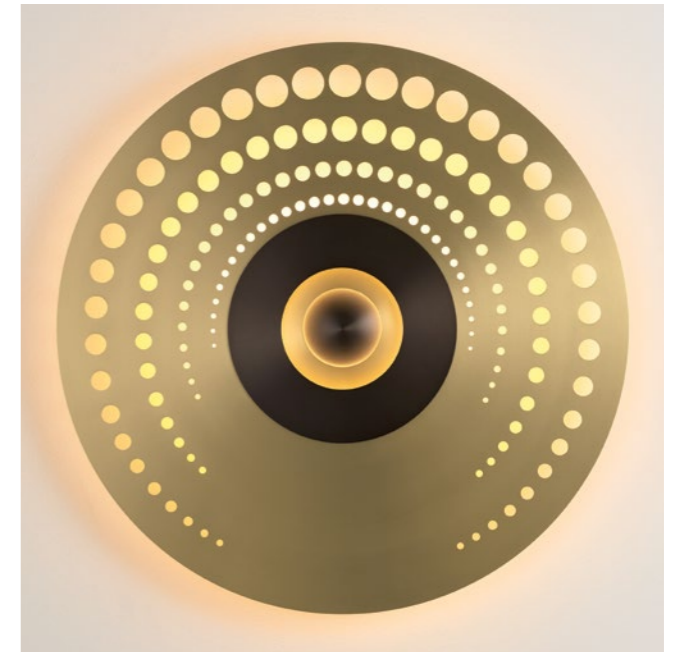

Atmos Pop SB/SG/SB/SG

Atmos Stella

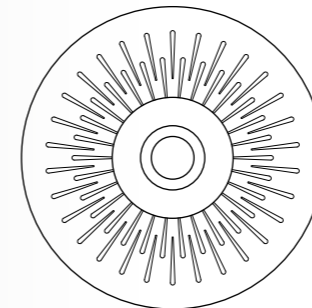

Ø 800 mm
Ø 31.5"



Atmos Stella SG/SB/SG/SB



Atmos Éclat SB/SG/SB/SG



Atmos Éclat SB/SG/SB/SG

Atmos Éclat

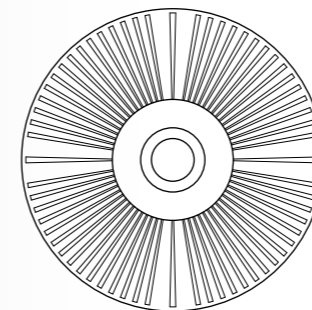

Ø 800 mm
Ø 31.5"

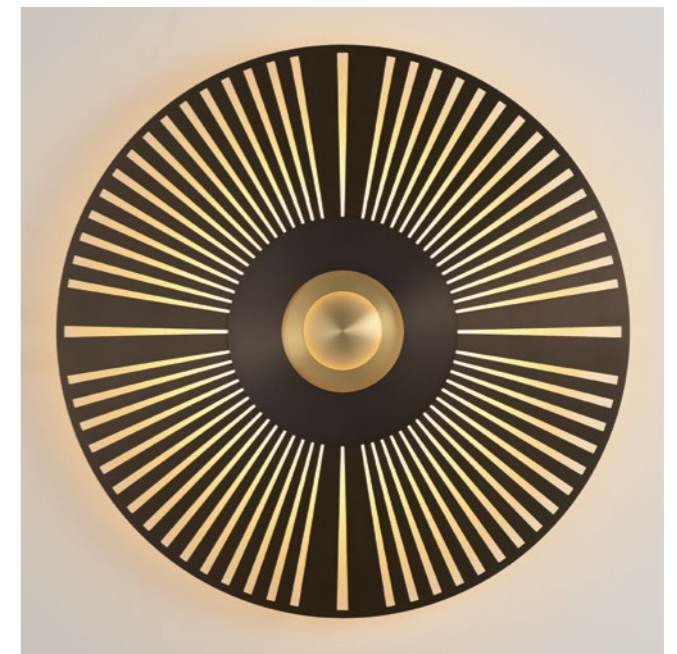

Atmos Éclat SG/SG/SB/SB



CALÉ(E)

Alphabet de formes, la collection *Calé(e)* se décline en jeu géométrique où le sens du déséquilibre forme des objets simples, linéaires et raffinés.







An assembly of designs, the *Calé(e)* collection offers a range of geometric patterns where the sense of imbalance forms simple, linear and sophisticated objects.









Finitions Finishes ① + ②

Détails page 239

Suspensions, lampes de table, lampadaires – Pendants, table and floor lamps

 Laiton satiné SB Satin brass	 Graphite satiné SG Satin graphite	 Nickel satiné SN Satin nickel	 Cuivre satiné SC Satin copper
---	--	--	--

Appliques – Wall mounted lights

 Laiton satiné SB Satin brass	 Graphite satiné SG Satin graphite	 Nickel satiné SN Satin nickel	 Cuivre satiné SC Satin copper
 Laiton poli PB Polished brass	 Graphite poli PG Polished graphite	 Nickel poli PN Polished nickel	 Cuivre poli PC Polished copper



Abat-jour Lampshade

Lampadaires, lampes de table – Table and floor lamps

 Chinette noire Black chinette	 Chinette blanche White chinette
--	--

Câble Cable

Suspensions – Pendants

 Tissu noir Black textile	 Tissu or (sur demande uniquement) Gold textile (on request only)
---	---

Matériaux Material

Tous – All
Laiton massif
Solid Brass

Suspensions, appliques, lampe XL
Pendants, wall lights, table lamp XL
Diffuseur en polycarbonate
Polycarbonate diffuser

Lampe de table XS, lampadaires
Table lamp XS, floor lamps
Abat-jour en tissu
Textile lampshade

Suspensions, lampes, lampadaires
Pendants, table & floor lamps
Câble textile (longueur ≈ 2 m)
Textile cable (length ≈ 78.7")

*La longueur standard des câbles est de 2 m mais elle peut être diminuée à l'installation. Autres longueurs sur demande.
The standard height of the cables is 2 m (78.7") but can be adjusted to less during installation. Custom heights available upon request.*

Description Features

Suspensions – Pendants

Il est possible de rassembler plusieurs suspensions sur un seul pavillon, circulaire ou rectangulaire. La version rectangulaire peut être adaptée à n'importe quelle longueur. La version circulaire a un diamètre maximum indiqué sur les croquis ci-après. Pour plus de renseignements, veuillez nous contacter.

It is possible to cluster several pendants from one single canopy, either rectangular or circular. The rectangular canopy can be custom-made into any size to suit your requirements. As for the circular canopy, available sizes are illustrated in the following pages. Please contact us for further information.

Designer

POOL

Source Lamping

Suspensions – Pendants

Suspension – Pendant V1

LED intégrée	1060 lm	2700°K	10W	Alim. électronique intégrée	Variation (phase cut)
Integrated LED	1060 lm	2700°K	10W	Int. power supply included	Dimmable (phase cut)
 Integrated LED	500 lm	2700°K	8W	Int. power supply included	Not dimmable

Suspension – Pendant V2

LED intégrée	1050 lm	2700°K	11W	Alim. électronique intégrée	Variation (phase cut)
Integrated LED	1050 lm	2700°K	11W	Int. power supply included	Dimmable (phase cut)
 Integrated LED	900 lm	2700°K	12W	Int. power supply included	Not dimmable

Suspension – Pendant V3

LED intégrée	1060 lm	2700°K	10W	Alim. électronique intégrée	Variation (phase cut)
Integrated LED	1060 lm	2700°K	10W	Int. power supply included	Dimmable (phase cut)
 Integrated LED	630 lm	2700°K	9W	Int. power supply included	Not dimmable

Suspension – Pendant V4

LED intégrée	1900 lm	2700°K	19W	Alim. électronique intégrée	Variation (phase cut)
Integrated LED	1900 lm	2700°K	19W	Int. power supply included	Dimmable (phase cut)
 Integrated LED	1500 lm	2700°K	19W	Int. power supply included	Not dimmable

Suspension – Pendant V5

LED intégrée	1920 lm	2700°K	24W	Alim. électronique intégrée	Variation (phase cut)
Integrated LED	1920 lm	2700°K	24W	Int. power supply included	Dimmable (phase cut)

Appliques – Wall lights

Appliques – Wall light VH, VV & VF

LED intégrée	960 lm	2700°K	10W	Alim. électronique 24V intégrée	Variation (phase cut)
Integrated LED	960 lm	2700°K	10W	Int. power supply 24V included	Dimmable (phase cut)

Spot XL (not available for 110V)

LED intégrée	630 lm	2700°K	10W	Alim. électronique intégrée	Variation (phase cut)
Integrated LED	630 lm	2700°K	10W	Int. power supply included	Dimmable (phase cut)

Lampes de table – Table lamps

Lampe – Lamp XL

LED intégrée	1000 lm	2700°K	10W	Alim. électronique intégrée	
Integrated LED	1000 lm	2700°K	10W	Int. power supply included	

Lampe – Lamp XS

1X E14 LED 7W max. non fournie	Interrupteur sur câble
1X E14 LED 7W max. not included	Cable switch

Lampadaires – Floor lamps

Lampadaires – Floor lamps XL

1X E27 LED 20W max. non fournie	Variateur à pied	Variation*
1X E27 LED 20W max. not included	Foot operated dimmer	Dimming*

Lampadaires – Floor lamps XS

1X E27 LED 20W max. non fournie	Variateur à pied	Variation*
1X E27 LED 20W max. not included	Foot operated dimmer	Dimming*

* Les luminaires variables nécessitent l'utilisation d'ampoules compatibles avec la variation.
All dimmable light fixtures require the use of compatible bulbs.

Suspensions – Pendants Calé(e) V5

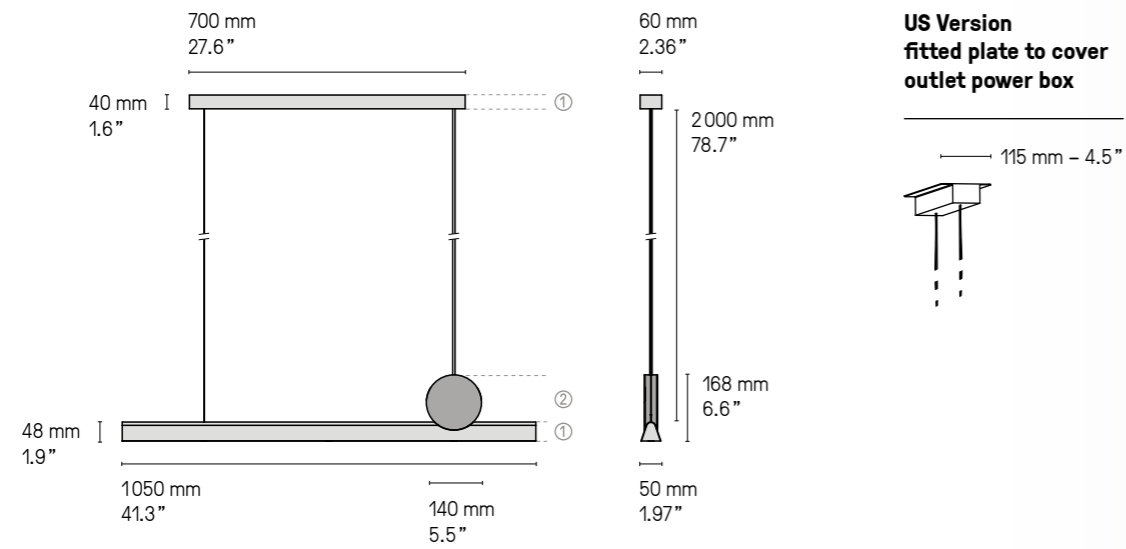

Calé(e) V5 SB/SG

La longueur standard des câbles est de 2 m mais elle peut être diminuée à l'installation. Autres longueurs sur demande.
The standard height of the cables is 2 m (78.7") but can be adjusted to less during installation. Custom heights available upon request.



Calé(e) V5 SB/SG

Suspensions – Pendants Calé(e)

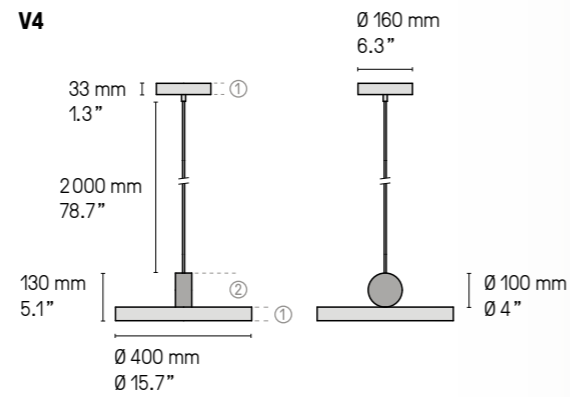
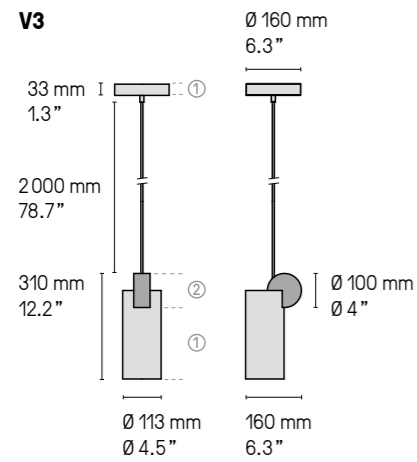
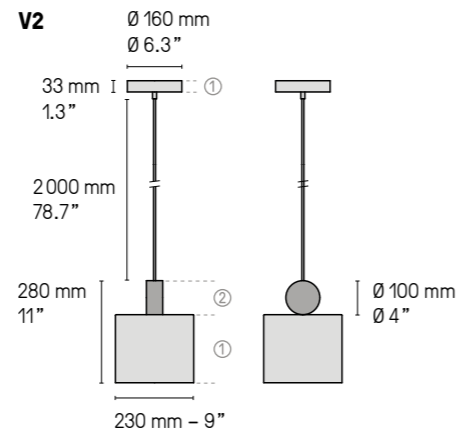
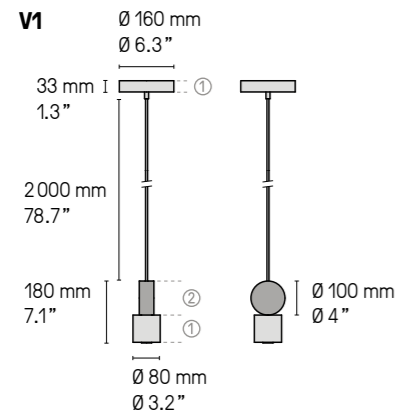

La longueur standard des câbles est de 2 m mais elle peut être diminuée à l'installation. Autres longueurs sur demande.
The standard height of the cables is 2 m (78.7") but can be adjusted to less during installation. Custom heights available upon request.

Le petit disque du dessous sera toujours en finition ①
The small centered disc on the bottom always comes in finish ①



Calé(e) V1 SB/SG
Installation sur mesure avec driver déporté.
Custom installation with remote driver.

Suspensions – Pendants Calé(e)

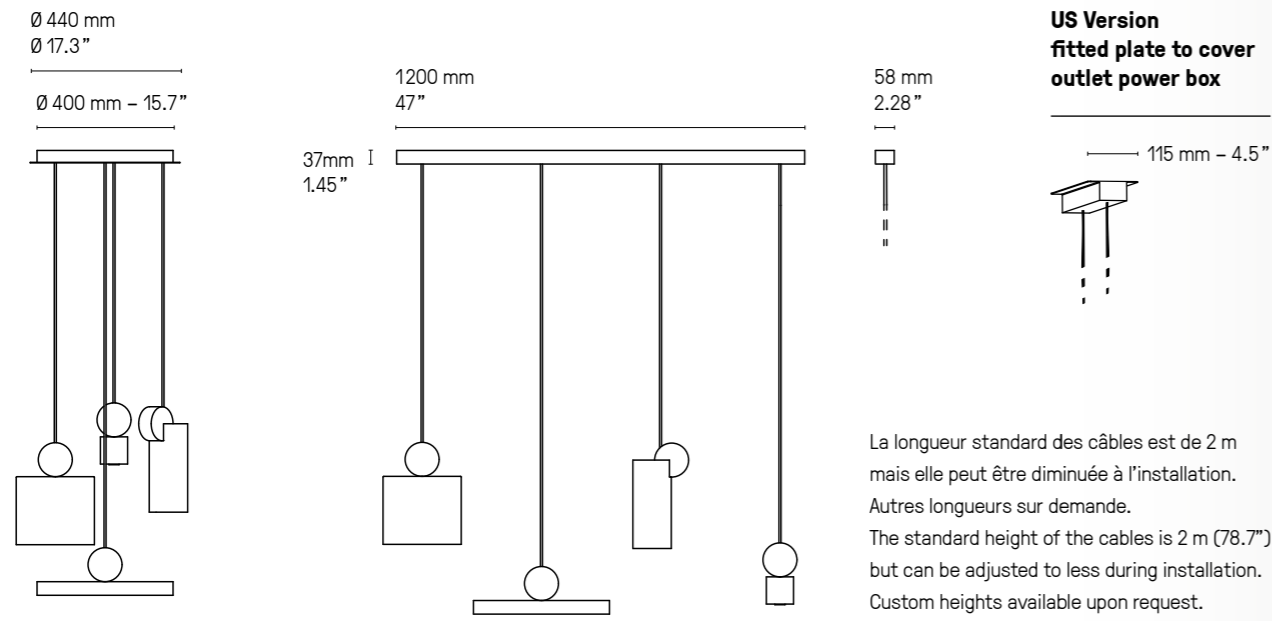

Calé(e) V2, V3 & V4 SB/SG



Calé(e) V1, V2 & V3 SG/SB



Applique – Wall light Calé(e) VF SB/SG



Applique – Wall light Calé(e) VV SG/SB

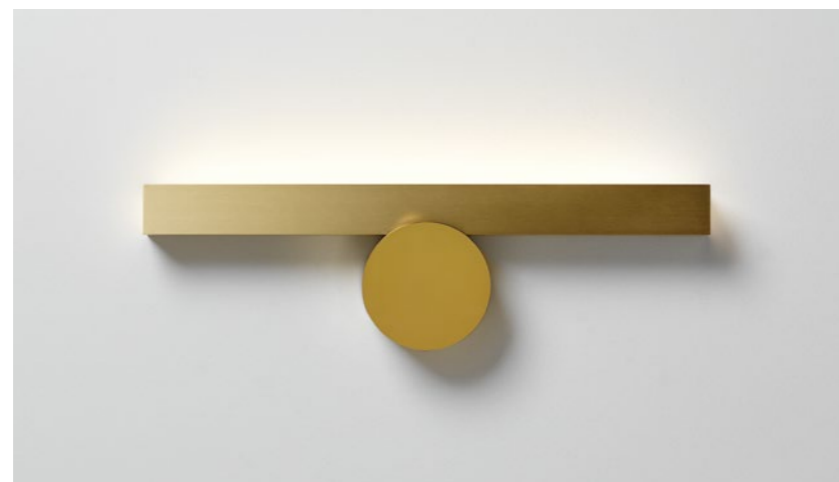

Applique – Wall light Calé(e) VH SB/PB

Appliques – Wall lights Calé(e)

VH

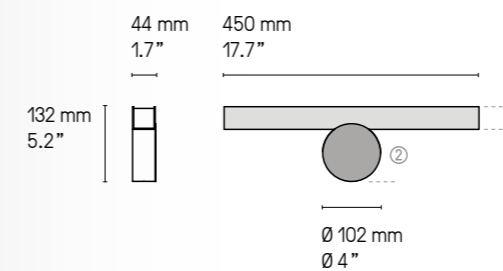

VV

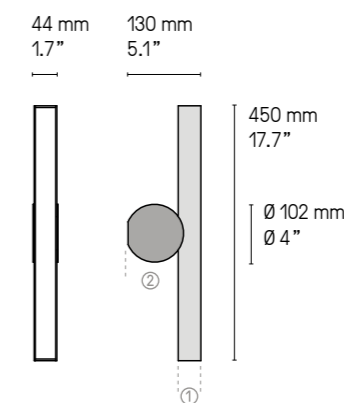

VF

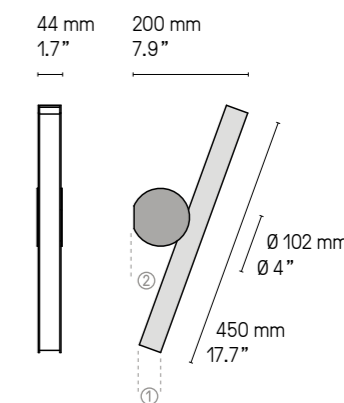

US Version
fitted plate to cover outlet power box

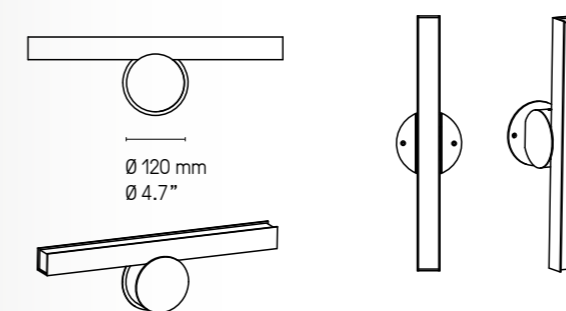

Les appliques Calé(e)s ne sont pas réglables. Ce sont 3 modèles différents.
Retrouvez les variantes salle de bain (IP44) de ces modèles p.212
Calé(e) wall lights are not mobile. These are 3 different fixed models.
You will find the bathroom variants (IP44) of these designs p.212

Spot XL

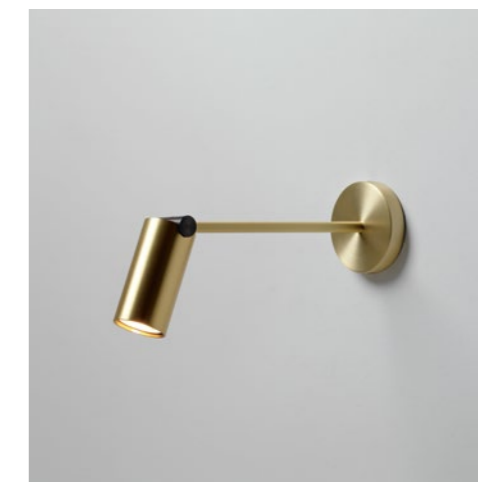
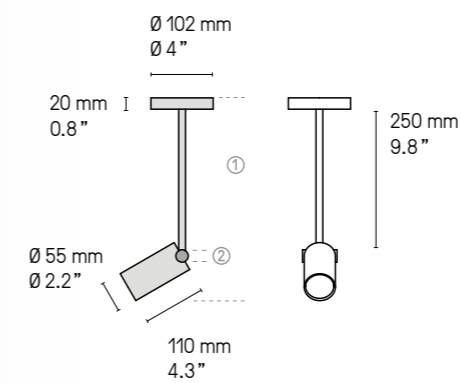

Spot Calé(e) XL SB/SG

Lampe de tables – Table lamps Calé(e)

XL

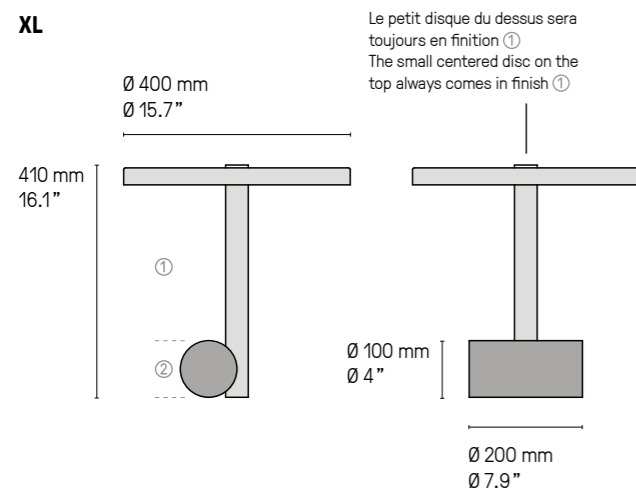

XS

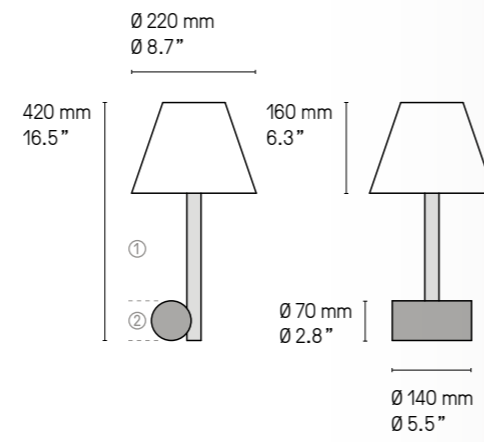

Lampe Calé(e) XS SN/SG





Lampadaire – Floor lamp Calé(e) XS SB/SB

Lampadaires – Floor lamp Calé(e)

XL

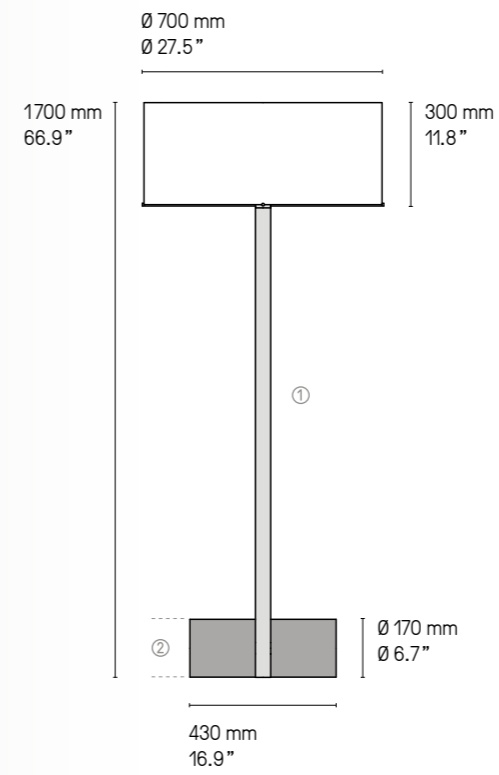

XS

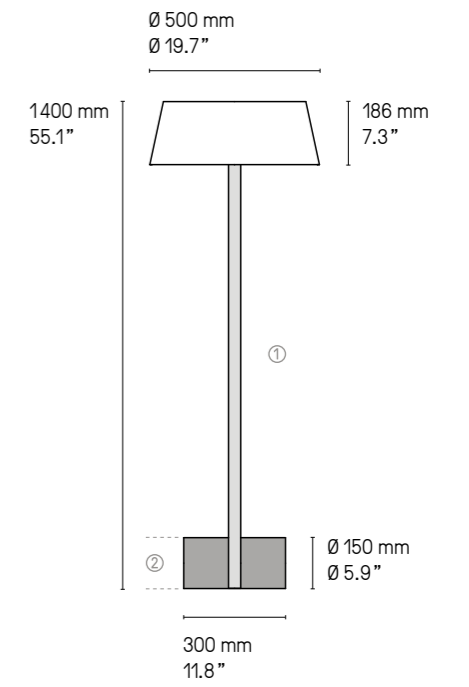

Version LED et DALI sur demande.
LED and DALI version upon request.



Calé(e) XL SB/SG



CERCLE & TRAIT

D'une apparente légèreté, les formes de *Cercle & trait* se frottent et se tiennent dans un jeu d'équilibre savamment dosé. Une suspension graphique déclinée en différentes finitions qui ne tient qu'à un fil.



As light as it looks, the forms of *Cercle & trait* rub together and hold together in a cleverly measured balance. A graphic pendant, available in different finishes, is just held by one small wire.

Finitions
Finishes

- Laiton satiné ● Graphite satiné ● Nickel satiné ● Cuivre satiné
- SB** Satin brass **SG** Satin graphite **SN** Satin nickel **SC** Satin copper

Détails page 239

Matériaux
Material

<p>Tous – All Laiton massif Solid Brass</p>	<p>Tous – All Diffuseur polycarbonate satiné Satin Polycarbonate diffuser</p>	<p>Potence applique – Deported wall light Câble textile noir + câble métallique Black textile cable + metal cable</p>
<p>Suspensions – Pendants Câble textile noir (longueur ≈ 1 m) Black textile cable (length ≈ 39.4")</p> <p><i>La longueur standard des câbles est de 1 mètre mais elle peut être diminuée à l'installation. The standard height of the cables is 1 meter (39.4") but can be adjusted to less during installation.</i></p>		<p>Lampadaire et liseuse – Floor and reading lamp Câble textile noir + cordon élastomère Black textile cable + elastomer cord</p>

Source
Lamping

Suspensions – Pendants				
Suspension – Pendant XL				
LED intégrée	1350 lm	2700°K	16W	Alim. 24V intégrée dans le pavillon
Integrated LED	1350 lm	2700°K	16W	Int. power sup. 24V incl. in canopy
Integrated LED	1350 lm	2700°K	19W	Int. power sup. 24V incl. in canopy
				Variable (phase cut)
				Dimmable (phase cut)
				Damp
Suspension – Pendant XS				
LED intégrée	930 lm	2700°K	12W	Alim. 24V intégrée dans le pavillon
Integrated LED	930 lm	2700°K	12W	Int. power sup. 24V incl. in canopy
				Variable (phase cut)
				Dimmable (phase cut)
Potences murales – Deported wall lights				
Potence murale – Deported wall light				
LED intégrée	1900 lm	2700°K	19W	Branchement avec prise
Integrated LED	1900 lm	2700°K	19W	Plug-in connection
				Variateur à main
				Hand operated dimmer
Potence murale – Deported wall light				
LED intégrée	1900 lm	2700°K	19W	Branchement mural
Integrated LED	1900 lm	2700°K	19W	Main connection
				Variable (phase cut)
				Dimmable (phase cut)
Lampadaires – Floor lamps				
Liseuse sur pied – Standing reading lamp				
LED intégrée	850 lm	2700°K	11W	Variateur à pied
Integrated LED	850 lm	2700°K	11W	Foot operated dimmer
Lampadaire – Floor lamp				
LED intégrée	5400 lm	2700°K	36W	Variateur à pied
Integrated LED	5400 lm	2700°K	36W	Foot operated dimmer

Designer POOL

*Cercle & trait est un projet sur le mouvement des formes et l'équilibre qui s'entremêlent.
Ce luminaire comme un mobile crée une lumière en mouvement.
Cercle & trait is a design between movement of forms and balance that intertwine.
Like a mobile this luminaire creates a light in motion.*



Cercle & trait XL SG

Cercle & trait XL

UL version suitable for damp location

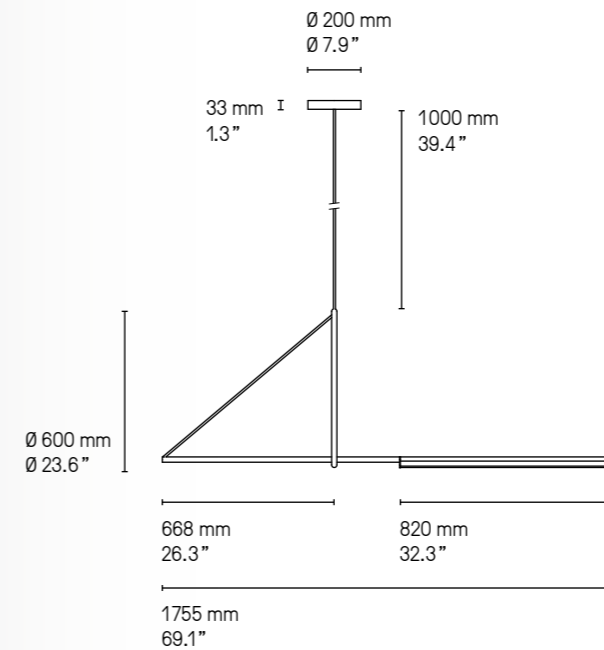

Cercle & trait XS

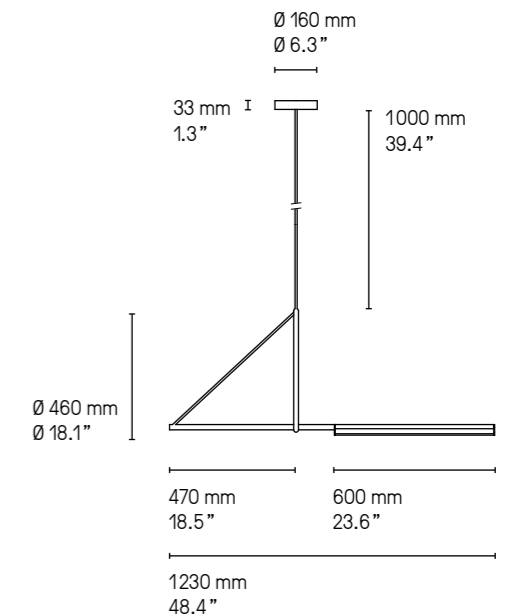

La longueur standard des câbles est de 1 m mais elle peut être diminuée à l'installation. Autres longueurs sur demande.
The standard height of the cables is 1 m (39.4") but can be adjusted to less during installation. Custom heights available upon request.



Cercle & trait Potence murale – Deported wall light

**Branchement avec prise
Plug-in connection**

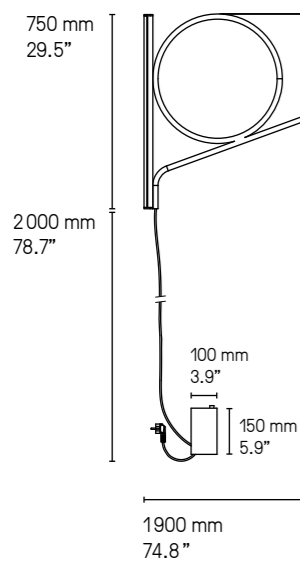

**Branchement mural
Mains connection**

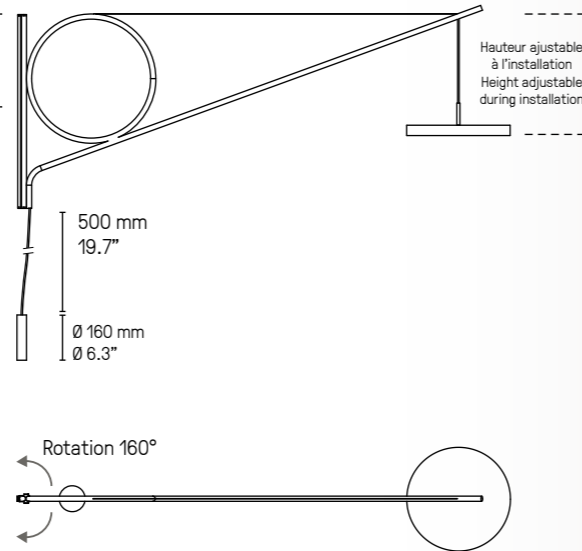

La longueur des câbles est ajustable à l'installation.
The height of the cables can be adjusted during installation.



Cercle & trait Potence murale prise – Deported light plug-in SG

Cercle & trait Liseuse sur pied – Standing reading lamp

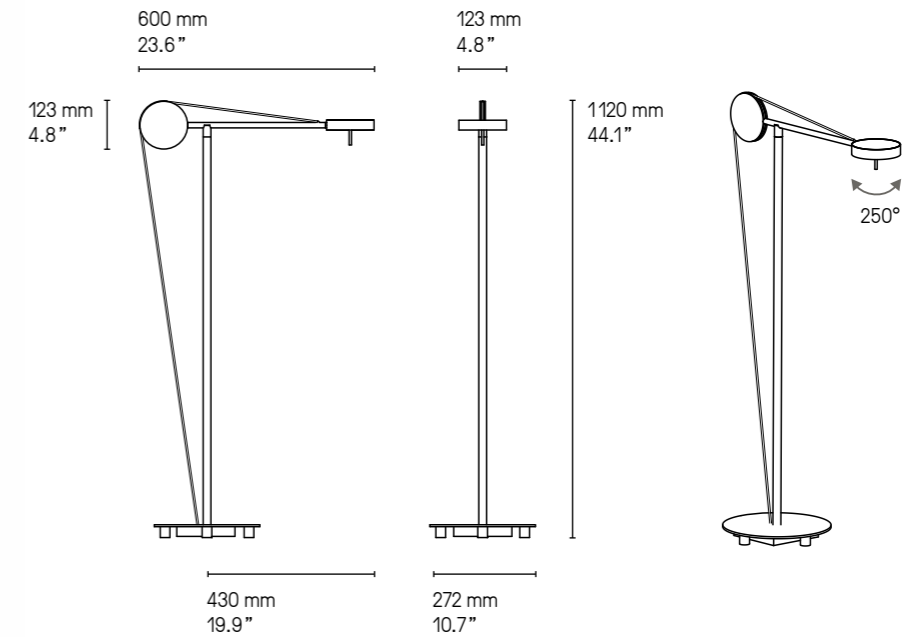



Cercle & trait Liseuse sur pied – Standing reading lamp SB

Cercle & trait Lampadaire – Floor lamp

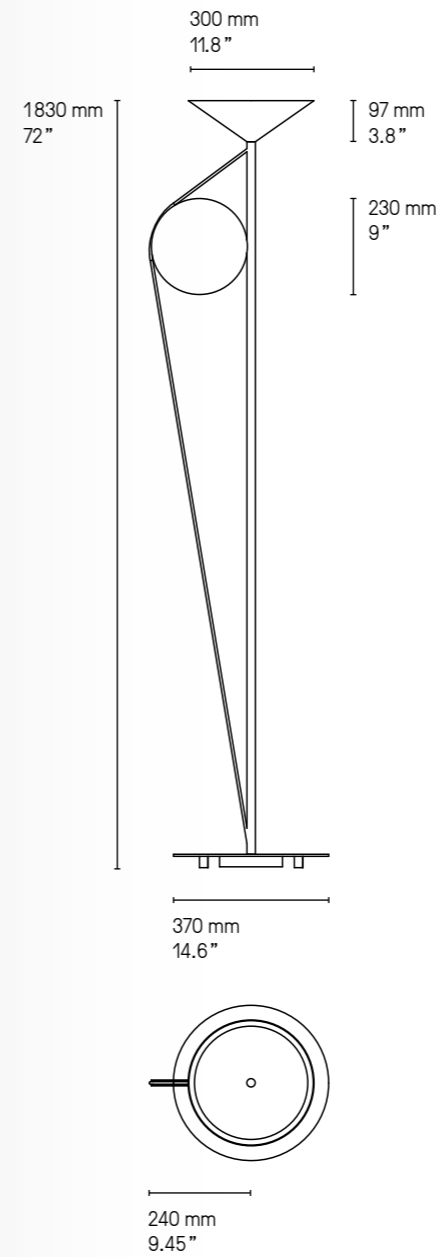

Cercle & trait Lampadaire – Floor lamp SG



COMPASS

Avec la collection *Compass*, le marbre blanc et le noyer massif font leur entrée chez CVL. L'applique orientable avec son éclairage ciblé, trouve sa place aussi bien en liseuse qu'en luminaire architectural tandis que la suspension *Compass*, sculpture flottante, délivre une lumière agréable grâce à son verre opalin.



With the *Compass* collection, CVL innovates with new materials: white marble and solid walnut. The rotating wall light, with its orientable lighting, finds its place just as well as a reading light or as an architectural fixture, whereas the *Compass* pendant, a floating sculpture, provides subtle light thanks to its opaline glass.

**Finitions
Finishes**

- Laiton satiné ● Graphite satiné ● Nickel satiné ● Cuivre satiné
- SB Satin brass SG Satin graphite SN Satin nickel SC Satin copper

- Noyer ● Marbre blanc
- NO Walnut MA White marble

Détails page 239

**Matériaux
Material**

<p>Tous – All Laiton massif Solid Brass Noyer massif ou Marbre Blanc Solid Walnut or White marble</p>	<p>Suspension – Pendant Verrerie Opale soufflée bouche Opal mouth-blown glass Câble textile noir (longueur ≈ 2 m) Black textile cable (length ≈ 78.7") <i>La longueur standard des câbles est de 2 mètres mais elle peut être diminuée à l'installation. The standard height of the cables is 2 meters (78.7") but can be adjusted to less during installation.</i></p>	<p>Applique – Wall light Diffuseur en polycarbonate Polycarbonate diffuser</p>
--	--	---

**Source
Lamping**

Suspension – Pendant				
LED intégrée	1060 lm	2700° K	10 W	Variation (phase cut)
Integrated LED	1060 lm	2700° K	10 W	Dimmable (phase cut)
Appliques – Wall light				
LED intégrée	331 lm	2700° K	4 W	Variateur tactile
Integrated LED	331 lm	2700° K	4 W	Touch dimmer

Designer

Émilie Cathelineau



Compass Applique – Wall light SB/MA

Compass Suspension – Pendant

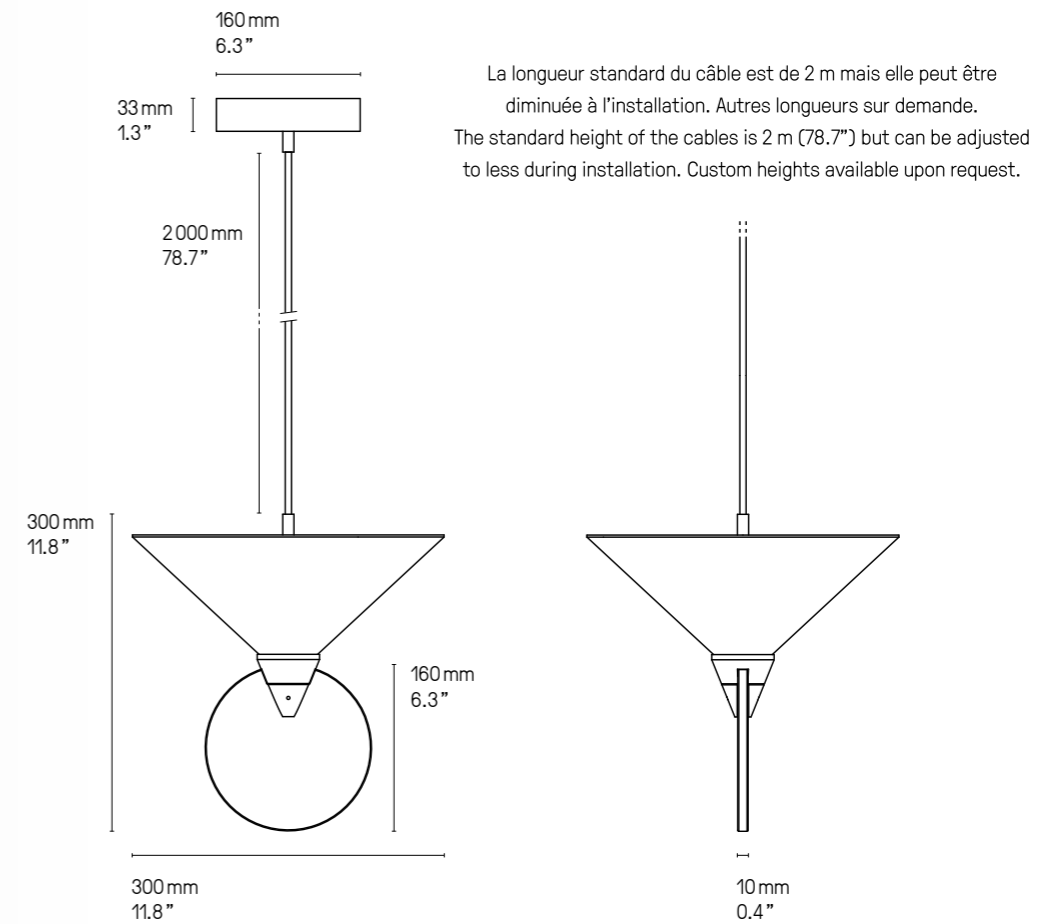

Compass Applique – Wall light

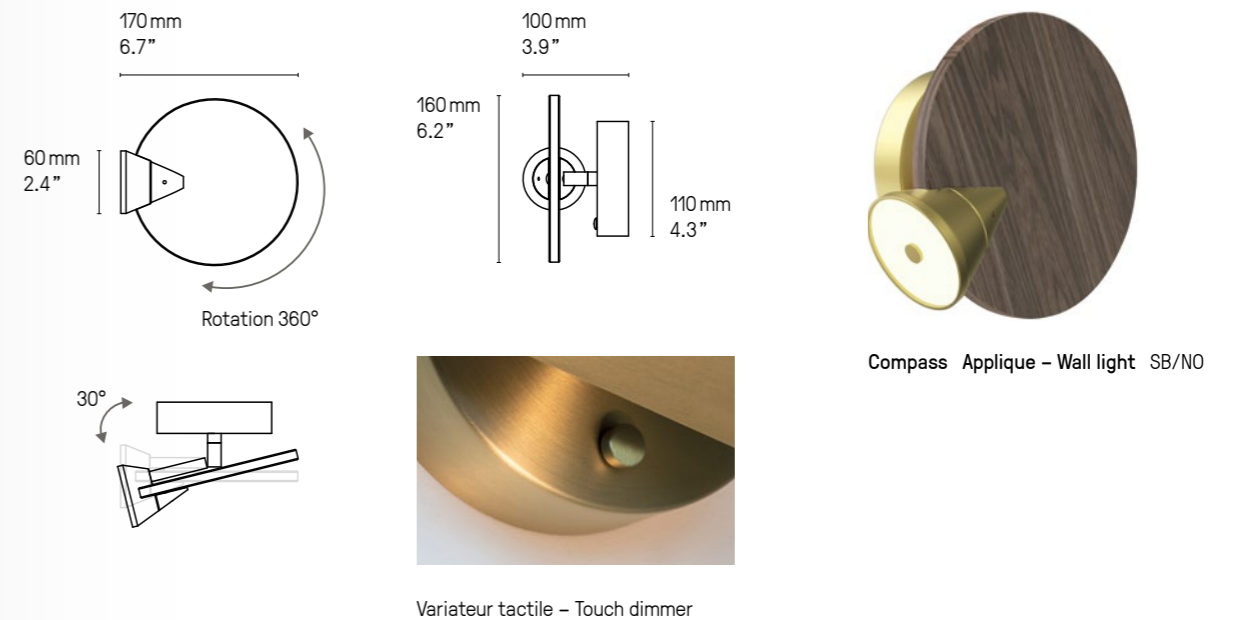



CONSTELLATION

Asymétrie et démultiplication, *Constellation* offre une infinité de possibilités à composer selon l'espace et vos inspirations. En mural ou au plafond, vos envies se dessinent en points lumineux.



Asymmetry and multiplying, *Constellation* offers an infinity of arrangement possibilities depending on the space and your inspirations. As a wall unit or a ceiling fixture, you can position the light any way you desire to.

Finitions
Finishes ①

Détails page 239

Finitions
Finishes ②

● Laiton satiné
SB Satin brass

● Graphite satiné
SG Satin graphite

● Nickel satiné
SN Satin nickel

● Laiton satiné
SB Satin brass

● Graphite satiné
SG Satin graphite

● Nickel satiné
SN Satin nickel

● Cuivre satiné
SC Satin copper

Matériaux
Material

Laiton massif
Solid Brass

Verre triplex opale soufflé bouche
Opal triplex mouth-blown glass

Source
Lamping

LED intégrée Integrated LED	6 x 120 lm 6 x 120 lm	3000°K 3000°K	6W 6W	Alimentation intégrée fournie Integrated power supply included <i>ou - or</i>	Variation. Veuillez nous contacter Dimming. Please, contact us
				Alimentation séparée fournie Remote power supply included	

	Integrated LED	6 x 120 lm	3000°K	6W	Integrated power supply included	Not dimmable	Damp
--	----------------	------------	--------	----	----------------------------------	--------------	------

Designer

Émilie Cathelineau

Alimentation intégrée
Integrated power supply

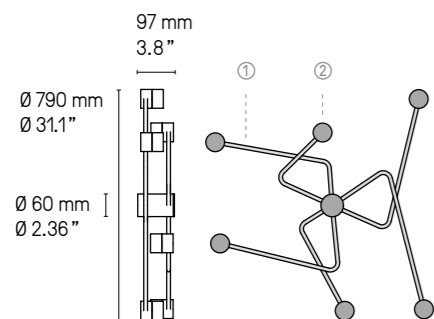

Alimentation séparée
Remote power supply

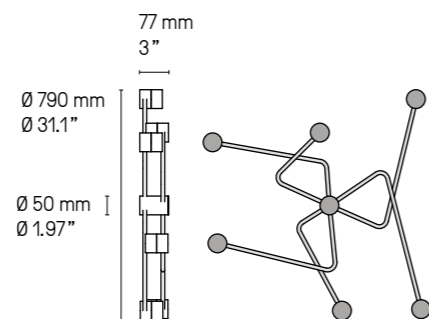

UL Version
fitted plate to cover outlet power box

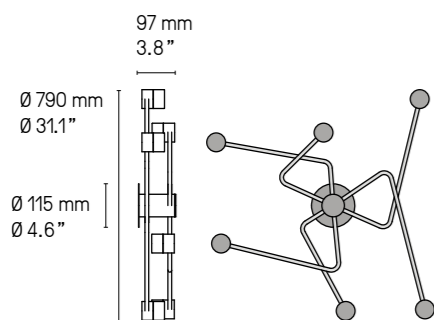

Constellation
SG/SB

Exemples de compositions, avec 3, 5 et 8 modules
Examples of arrangements, with 3, 5 or 8 units

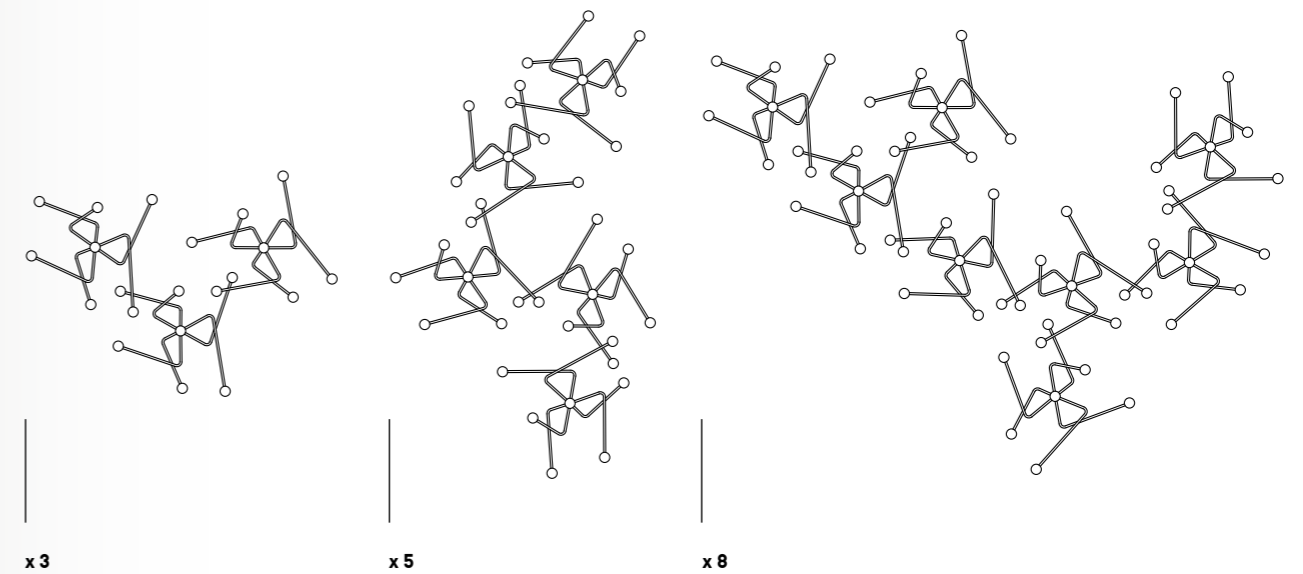

Version interconnectée
Interconnected version

Ce système d'interconnection ne nécessite qu'une seule sortie électrique. Veuillez noter que cette version interconnectée n'est pas certifiée UL et que les points de connections ne sont pas lumineux. Merci de nous contacter pour connaître les compositions possibles.

The new interconnection system requires only one electrical outlet. Please be aware that this interconnected system is not UL certified and that the connection points have no light. Contact us for more information on possible arrangements.

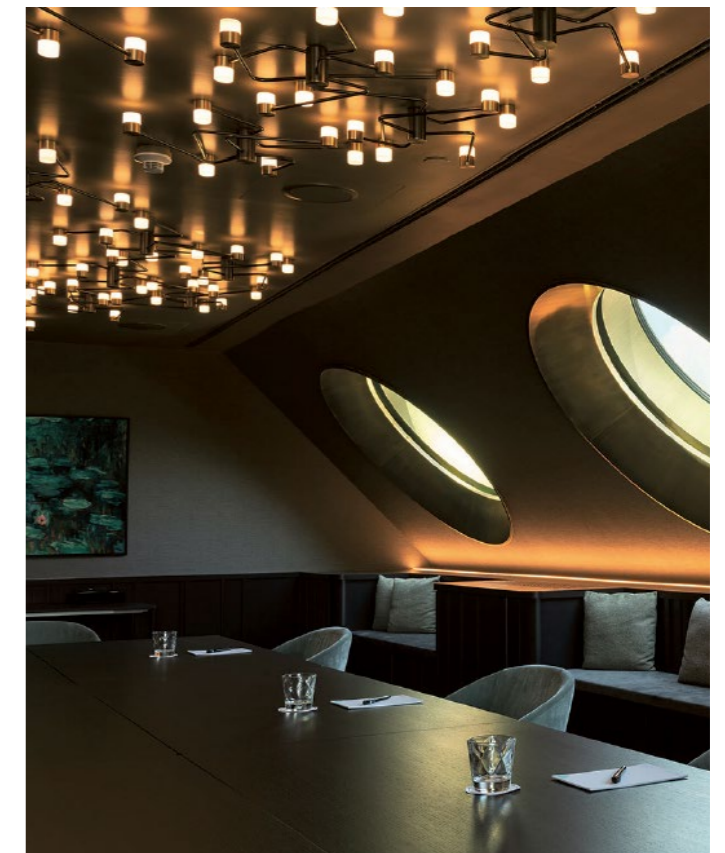
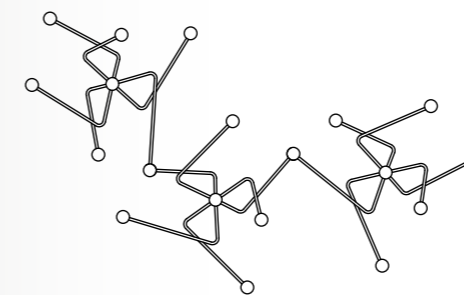

Constellations SG/SB indépendantes



CORNET

Luminaire à la fois minimaliste et ludique grâce à la technique du pliage du laiton. Chacune des facettes met la matière en valeur. La suspension, au design ovale et conique, peut accueillir trois ou cinq boules en verre opale.







A light that is both minimalist and playful thanks to the technique of folding the material of brass. Each of the facets really highlight the material. The pendant, with an oval and conical design, can accommodate three or five opal glass balls.









**Finitions
Finishes**

Détails page 239

Suspensions – Pendants

- | | | | |
|---|---|---|---|
|  Laiton satiné |  Graphite satiné |  Nickel satiné |  Cuivre satiné |
| SB Satin brass | SG Satin graphite | SN Satin nickel | SC Satin copper |

Appliques – Wall mounted lights

- | | | | |
|---|---|---|---|
|  Laiton satiné |  Graphite satiné |  Nickel satiné |  Cuivre satiné |
| SB Satin brass | SG Satin graphite | SN Satin nickel | SC Satin copper |
|  Laiton poli |  Graphite poli |  Nickel poli |  Cuivre poli |
| PB Polished brass | PG Polished graphite | PN Polished nickel | PC Polished copper |

**Matériaux
Material**

Tous – All

- | | |
|---------------|---------------------|
| Laiton massif | Verre triplex opale |
| Solid Brass | Opal triplex glass |

Suspensions – Pendants

- Câble textile noir + câble métallique (longueur ≈ 2 m)
Black textile cable + metal cable (length ≈ 78.7")

*La longueur standard des câbles est de 2 mètres
mais elle peut être diminuée à l'installation.
The standard height of the cables is 2 meters (78.7")
but can be adjusted to less during installation.*

**Source
Lamping**

Suspension – Pendant light

Suspension CORNET 3L

- G9 Led 3x 5W max. non fournie
G9 Led 3x 5W max. not included

Variable*

Variable*

Dimmable*

Dimmable*

Suspension CORNET 5L

- G9 Led 5x 5W max. non fournie
G9 Led 5x 5W max. not included

Variable*

Variable*

Dimmable*

Dimmable*

Appliques – Wall lights

Appliques – Wall mounted lights

- G9 LED 5W max. non fournie
G9 LED 5W max. not included

Variable*

Norme IP24 Classe II

Dimmable*

IP24 Class II standard

Designer

POOL

* Les luminaires variables nécessitent l'utilisation d'ampoules compatibles avec la variation.
All dimmable light fixtures require the use of compatible bulbs.

Cornet 5 L Suspension – Pendant

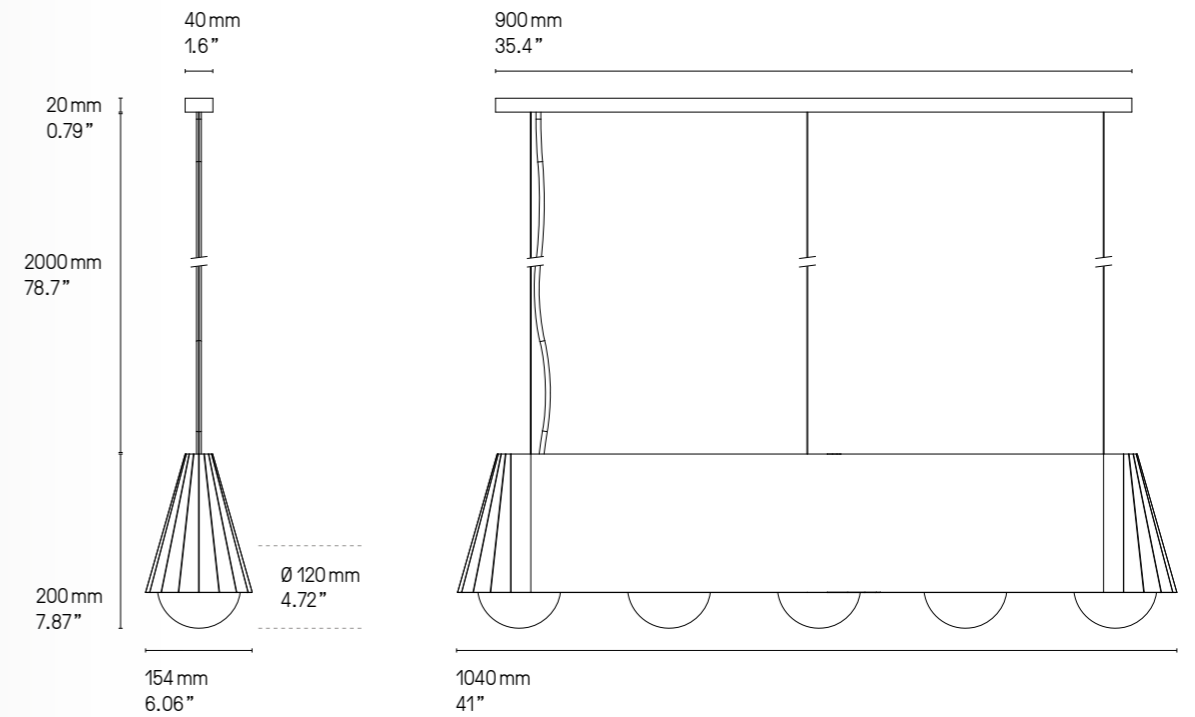

Cornet 3 L Suspension – Pendant

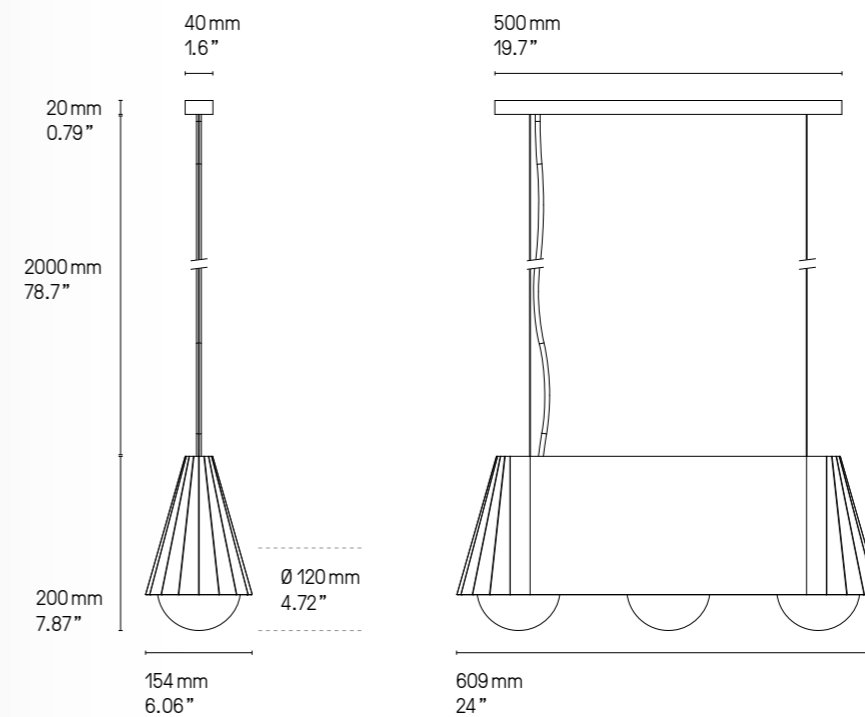

La longueur standard des câbles est de 2 m mais elle peut être diminuée à l'installation. Autres longueurs sur demande.
The standard height of the cables is 2 m (78.7") but can be adjusted to less during installation. Custom heights available upon request.



Suspension – Pendant light Cornet 3 L SB

Cornet Appliques – Wall mounted lights

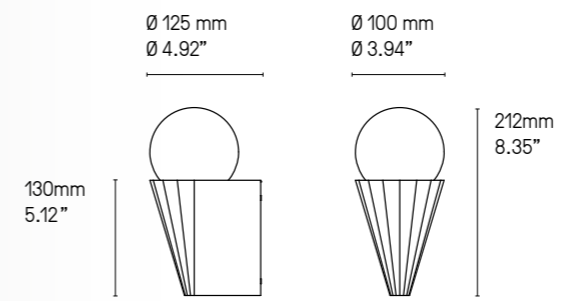

Retrouvez les variantes salle de bain (IP24) de ces modèles p.214
 You will find the bathroom variants (IP24) of these designs p.214



Cornet SC



Cornet SN



Applique – Wall mounted light Cornet SG



COUTURE









Discrète et raffinée, *Couture* est une petite lampe à poser dont l'abat-jour est tout simplement boutonné sur sa tige courbée en laiton.

Sa silhouette toujours changeante, à l'élégance classique, en fait une pièce maîtresse pour un intérieur.



Discrete and refined, *Couture* is a small table lamp with a shade that is simply buttoned to its curved brass stem.

Its ever-changing profile and classic elegance make it a stylish piece for interiors.

Finitions Finishes	 Laiton satiné	 Graphite satiné	 Nickel satiné	 Cuivre satiné
	SB Satin brass	SG Satin graphite	SN Satin nickel	SC Satin copper
<small>Détails page 239</small>	 Laiton poli	 Graphite poli	 Nickel poli	 Cuivre poli
	PB Polished brass	PG Polished graphite	PN Polished nickel	PC Polished copper

Abat-jour Lampshade	<input type="checkbox"/> Drop Paper® 100	<input checked="" type="checkbox"/> Drop Paper® 101	<input type="checkbox"/> Chinette blanche White chinette
--------------------------------------	--	---	---

Matériaux Material	Laiton massif Solid Brass	Abat-jour Drop Paper® M1 Lampshade Drop Paper® M1	Câble textile noir (longueur ≈ 2 m) Black textile cable (length ≈ 78.7")
-------------------------------------	------------------------------	--	---

Source Lamping	1 x E14 LED 7W max. non fournie 1 x E14 LED 7W max. not included	Interrupteur sur câble Cable switch
---------------------------------	---	--

Designer	Hervé Langlais
-----------------	----------------

Lampe de table – Table lamp

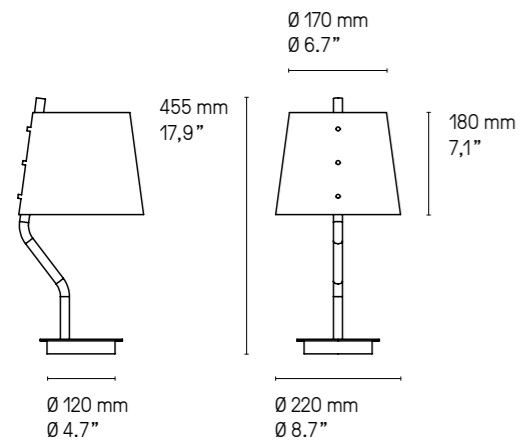

En standard, le dessous de la base sera toujours en finition graphite, si vous préférez une autre finition, merci de le préciser.

As standard, the underside of the base always comes in a satin graphite finish unless specified differently.



Lampe de table – Table lamp Couture SG



Lampe de table – Table lamp Couture SB



EARTH

Un cœur lumineux, serti d'un métal ajouré de manière extrêmement fine ou d'un disque plein, confère à cette collection une touche Art déco. Du clair-obscur au moucharabieh, les idées de composition sont variées.



This wall light, with an illuminated center, assembled with an extremely fine openwork or a fully covered piece of metal gives this collection an Art déco style. From semi-darkness to a patterned light source, arrangements can vary.

Finitions
Finishes ①+②

- Laiton satiné
SB Satin brass
- Graphite satiné
SG Satin graphite
- Nickel satiné
SN Satin nickel
- Cuivre satiné
SC Satin copper

Détails page 239

Matériaux
Material

Laiton massif / Solid brass
Diffuseur en polycarbonate / Polycarbonate diffuser

Source
Lamping

LED intégrée	1030 lm	2700°K	13W	Alim. électronique 24V intégrée	Variation (phase cut)	
Integrated LED	1030 lm	2700°K	13W	Integrated 24V power supply	Dimmable (phase cut)	
Integrated LED	1030 lm	2700°K	15W	Integrated 24V power supply	Dimmable (phase cut)	Damp

Designer

Émilie Cathelineau

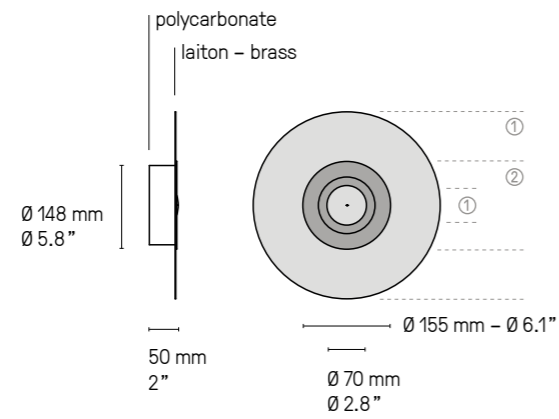

Partie centrale identique pour tous les modèles, quels que soient la taille et le motif.
Identical central part for all *Earth* fixtures for any size and design.

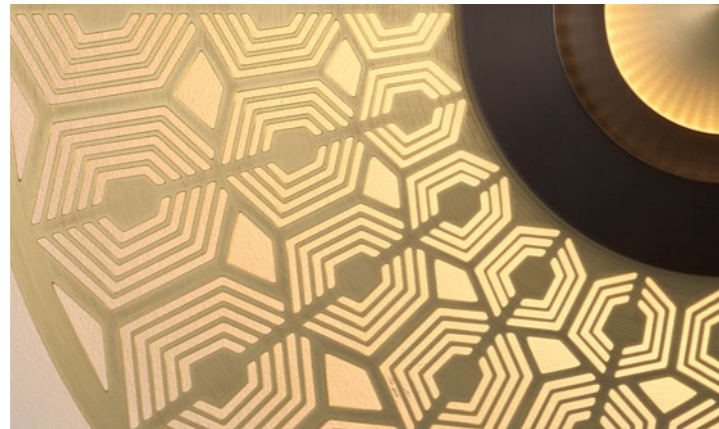

Earth Turtle 440 SB/SG

Earth Sober Ø 250 & Ø 330 mm

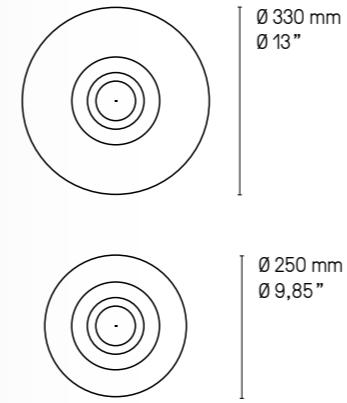

Earth Sober 330 SN/SG

Earth Éclat Ø 330 & Ø 440 mm

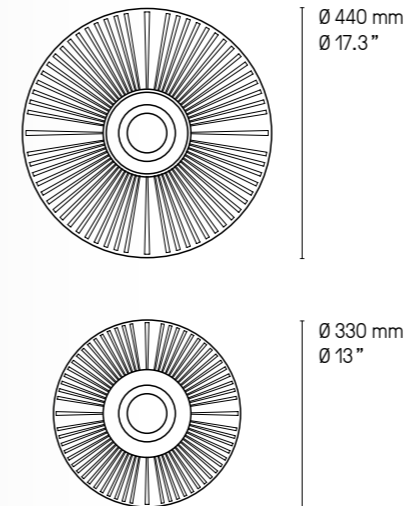

Earth Éclat 330 SB/SG

Earth Mandala Ø 330 & Ø 440 mm

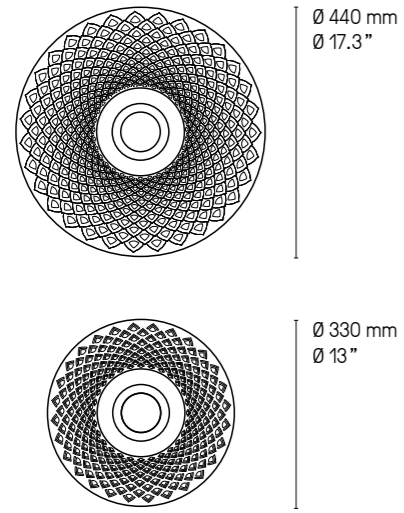

Earth Mandala 330 SB/SG

Earth Sun Ø 330 & Ø 440 mm

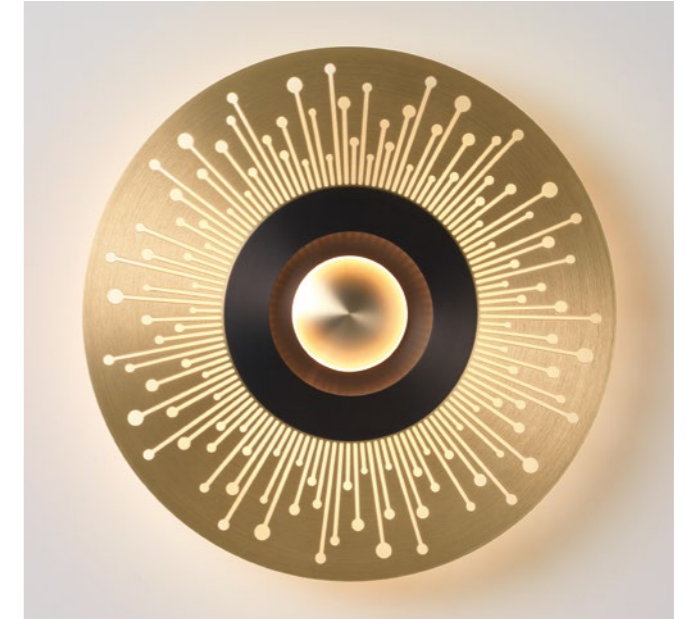
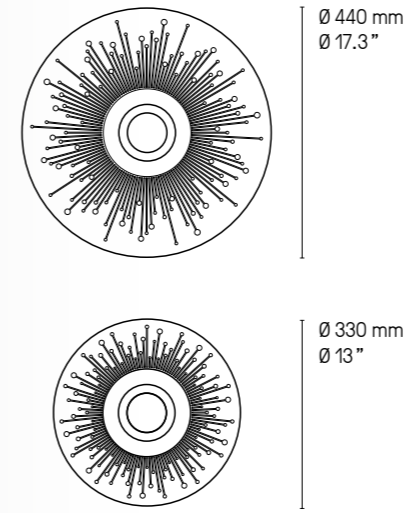

Earth Sun 330 SB/SG

Earth Palm Ø 330 & Ø 440 mm

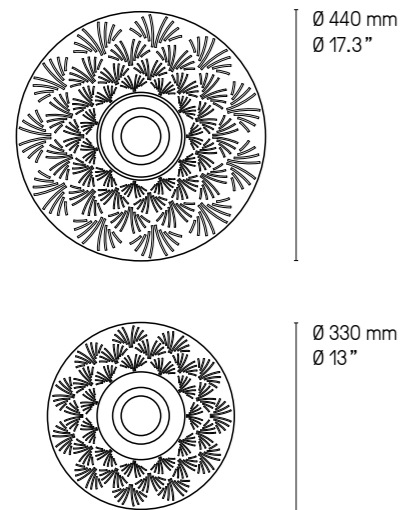

Earth Palm 330 SB/SG

Earth Turtle Ø 330 & Ø 440 mm

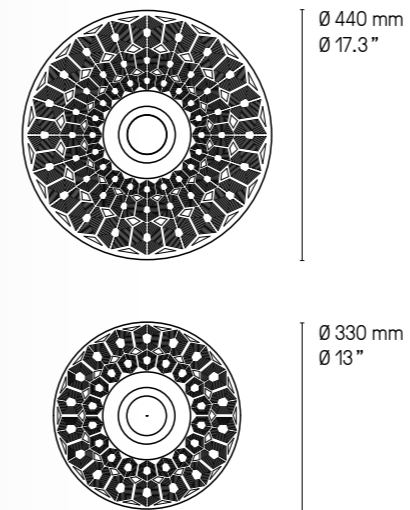

Earth Turtle 330 SG/SB

Earth Racine Ø 330 & Ø 440 mm

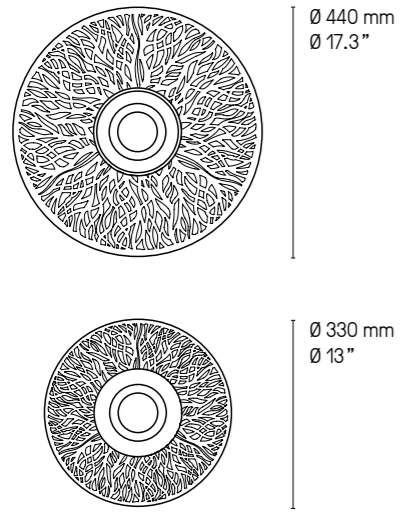

Earth Racine 330 SB/SG

Earth Radian Ø 350 mm

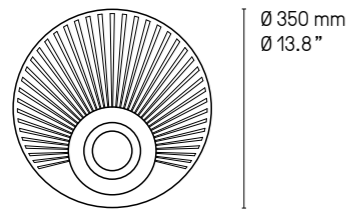

Earth Radian 350 SG/SB

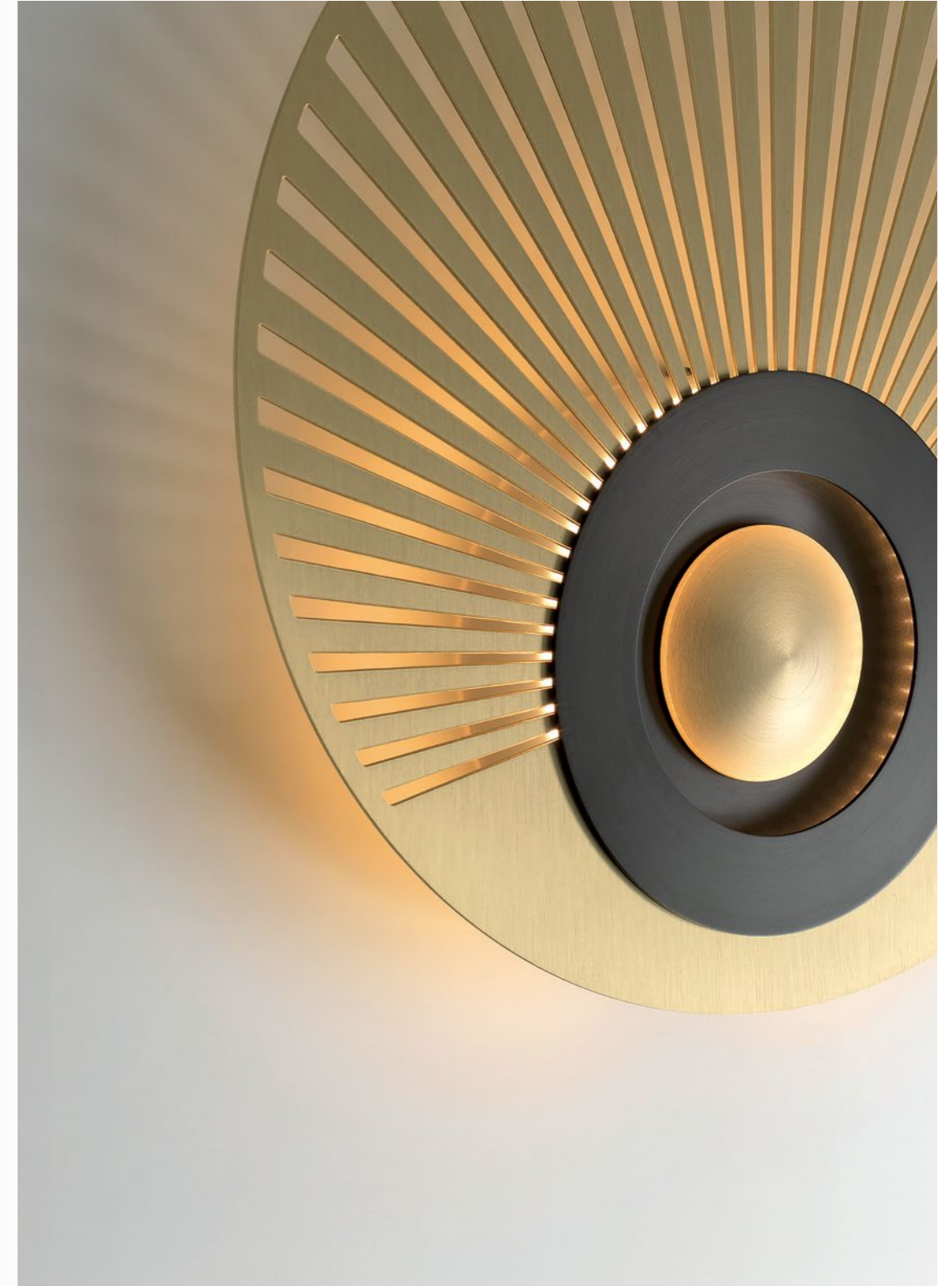

Earth Radian 350 SB/SG



ÉCLIPSE

Gamme d'appliques proposée en deux diamètres, *Éclipse* joue avec l'effet de disparition entre sa dalle de LED et ses deux disques en laiton. Un objet céleste qui ensoleille les architectures.



A range of wall light available in two diameters, *Éclipse* plays with the disappearing effect between its LED slab and its two brass discs. A celestial object to brighten up architecture..

Finitions
Finishes ①+②

Détails page 239

- Laiton satiné
SB Satin brass
- Graphite satiné
SG Satin graphite
- Nickel satiné
SN Satin nickel
- Cuivre satiné
SC Satin copper

En standard, le petit disque au centre du produit sera toujours en finition ① polie.
Si vous préférez une finition satinée, merci de le préciser.
The small centered disc on the front always comes in a polished finish ① but can be in satin if specified.

Matériaux
Material Laiton massif
Solid Brass

Description
Features L'applique *Éclipse* est fixe. Une fois positionnée au mur, elle ne peut pas tourner.
Please be aware that discs are fixed and cannot be positioned in any other way.

Source
Lamping LED intégrée 1600 lm 3 000°K 12W Alim. électronique intégrée Variation (phase cut)
Integrated LED 1600 lm 3 000°K 12W Integrated power supply Dimmable (phase cut)

Designer Hervé Langlais

Éclipse XL

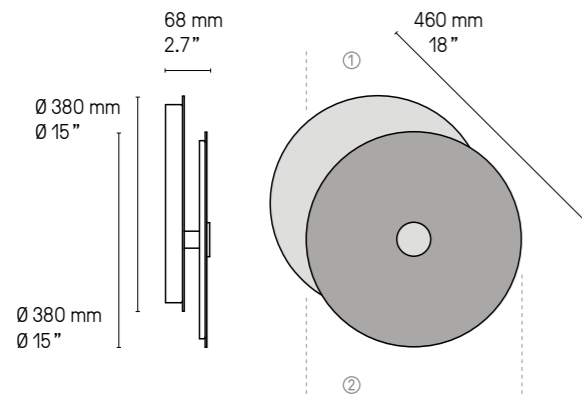

Éclipse XS

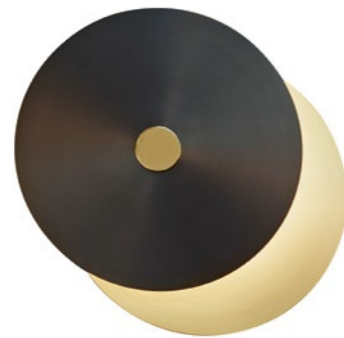
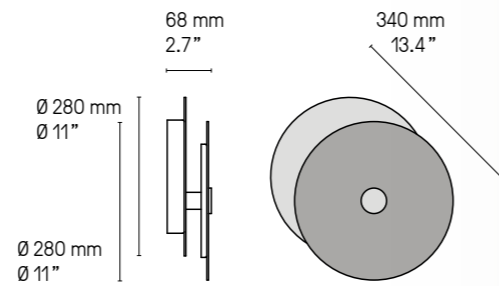

Eclipse XL SB/SG

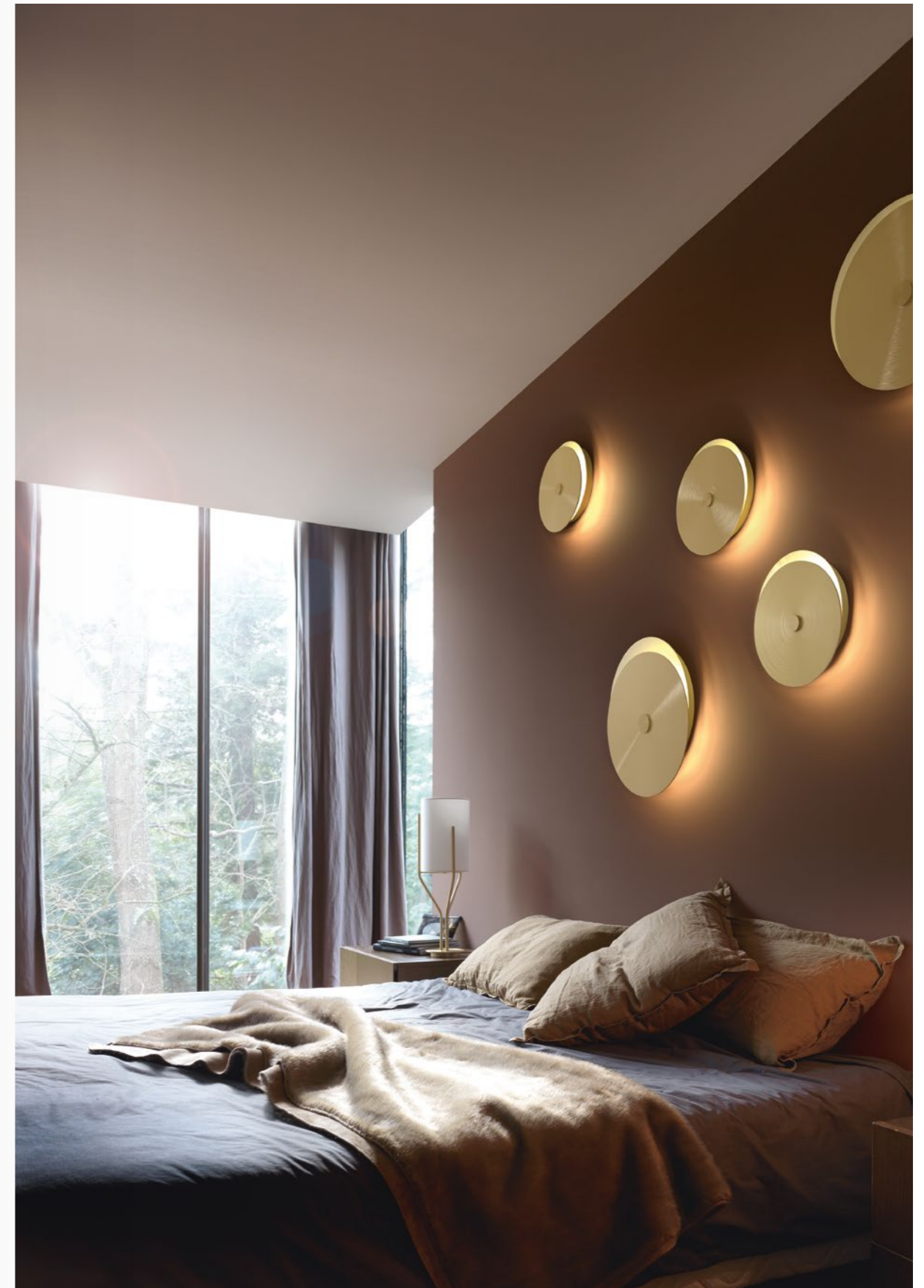

Eclipse XS + XL SB/SB



EXTRA

Extra, par Sylvain Willenz, est une série de luminaires faite de profilés carrés et ronds imbriqués les uns dans les autres de façon à créer, en toute simplicité, de nouvelles formes et typologies aux géométries essentielles.



Extra, by Sylvain Willenz, is a series of lightings made of square and round tubes, assembled together to create new shapes and arrangements with simple yet essential geometries.

Finitions
Finishes ①+②

- Laiton satiné
SB Satin brass
- Graphite satiné
SG Satin graphite
- Nickel satiné
SN Satin nickel
- Cuivre satiné
SC Satin copper

Détails page 239

Matériaux
Material

Laiton massif
Solid Brass

Câble textile (longueur ≈ 2 m)
Textile cable (length ≈ 78.7")

*La longueur standard des câbles est de 2 mètres mais elle peut être diminuée à l'installation.
The standard height of the cables is 2 meters (78.7") but can be adjusted to less during installation.*

Source
Lamping

1 x GU10 PAR16 non fournie (ex.: 4 W = 450 lm) Variable*
1 x GU10 PAR16 not included (ex.: 4 W = 450 lm) Dimmable*

Designer

Sylvain Willenz

* Les luminaires variables nécessitent l'utilisation d'ampoules compatibles avec la variation.
All dimmable light fixtures require the use of compatible bulbs.



Extra V1 SG/SB



Extra V2 SB/SG



Extra V3 SG/SB



Extra V4 SB/SG

Extra Suspension – Pendant

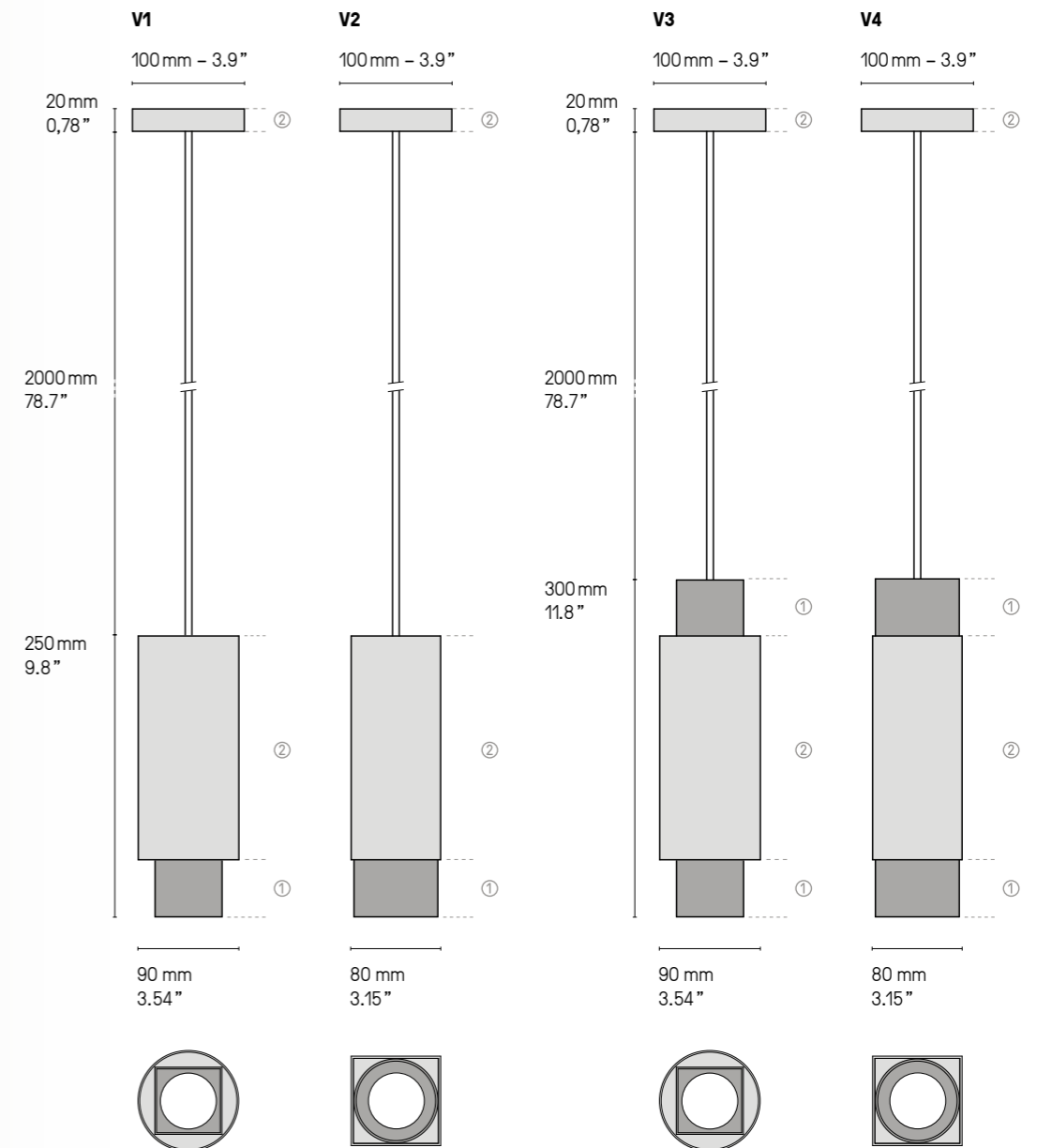

US Version
fitted plate to cover
outlet power box

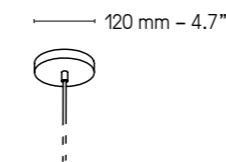

La longueur standard du câble est de 2 m mais elle peut être diminuée à l'installation. Autres longueurs sur demande.
The standard height of the cables is 2 m (78.7") but can be adjusted to less during installation. Custom heights available upon request.



FLÉA

Fléa est une petite applique suspendue en forme de trompette. À son extrémité, une verrerie facettée renvoie de subtils jeux de lumière sur le mur. Elle se décline également en suspension, seule ou à multiplier.



Flea is a small suspended trumpet-shaped wall light. Its faceted glassware subtly displays lighting effects onto the wall. It is also available as a pendant, alone or in combination.

Finitions
Finishes

● Laiton satiné
SB Satin brass

● Graphite satiné
SG Satin graphite

● Nickel satiné
SN Satin nickel

● Cuivre satiné
SC Satin copper

Détails page 239

Câble
Cable

■ Tissu noir
Black textile

■ Tissu or (sur demande uniquement)
Gold textile (on request only)

La longueur standard des câbles est de 2 m, pour les suspensions et 15 cm pour les appliques mais elle peut être diminuée à l'installation. Autres longueurs sur demande.
The standard height of the cables is 2 m (78.7") for a pendant and 150 mm (5.9") for a wall light it can be adjusted to less during installation. Custom heights available upon request.

Matériaux
Material

Laiton massif
Solid Brass

Verrerie soufflée bouche
Mouth-blown glass

Câble textile
Textile cable

Source
Lamping

G9 LED 5W max. non fournie
G9 LED 5W max. not included

Variation*
Dimming*

This collection is not available for the USA.

Designer
Émilie Cathelineau

* Les luminaires variables nécessitent l'utilisation d'ampoules compatibles avec la variation.
All dimmable light fixtures require the use of compatible bulbs.

Applique – Wall light

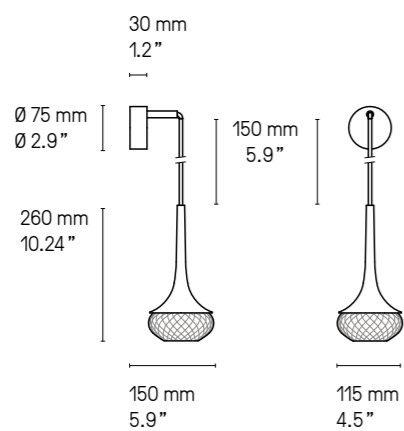

Applique – Wall light Fléa SB

La longueur standard des câbles est de 2 m pour les suspensions et 150 mm pour les appliques mais elle peut être diminuée à l'installation. Autres longueurs sur demande.
The standard height of the cables is 2 m (78.7") for a pendant and 150 mm (5.9") for a wall light but can be adjusted to less during installation. Custom heights available upon request.

Suspension – Pendant

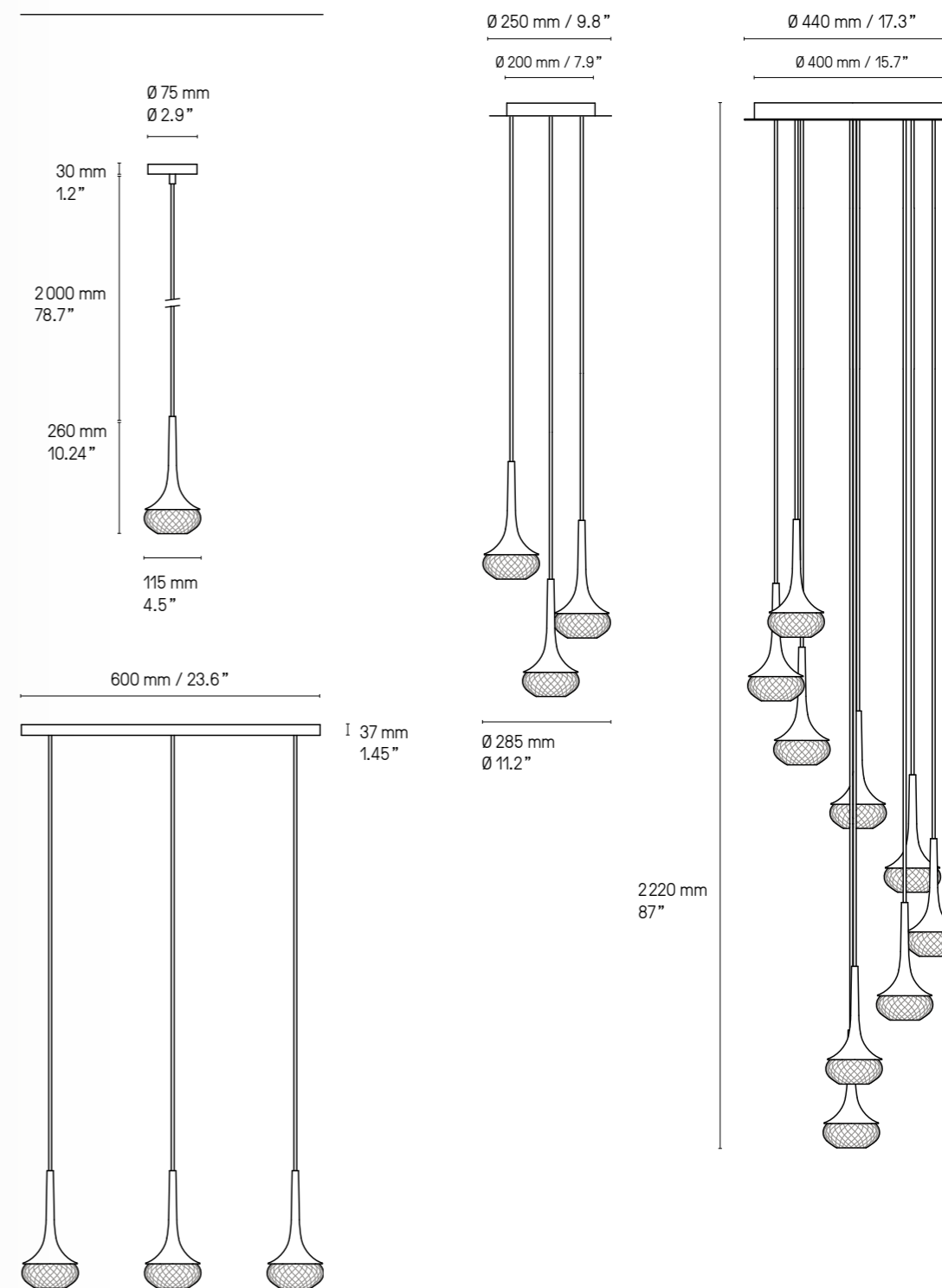

Il est possible de rassembler plusieurs suspensions sur un seul pavillon, circulaire ou rectangulaire. La version rectangulaire peut être adaptée à n'importe quelle longueur. La version circulaire a un diamètre maximum indiqué sur les croquis ci-dessus. Pour plus de renseignements, veuillez nous contacter.
It is possible to cluster several pendants from one single canopy, either rectangular or circular. The rectangular canopy can be custom-made into any size to suit your requirements. As for the circular canopy, available sizes are illustrated above. Please contact us for further information.



GAMMA

Gamma est un système graphique et versatile. C'est à partir de tubes métalliques et de cylindres blancs opalins, multipliés, que s'agence ainsi toute une gamme de luminaires.



Gamma is a striking and versatile lighting system. The design of this collection is based on the multiplication of metal tubes and opal white luminous cylinders, assembled like a chain.

**Finitions
Finishes**

Détails page 239

● Laiton satiné SB Satin brass	● Graphite satiné SG Satin graphite	● Nickel satiné SN Satin nickel	● Cuivre satiné SC Satin copper
● Laiton poli PB Polished brass	● Graphite poli PG Polished graphite	● Nickel poli PN Polished nickel	● Cuivre poli PC Polished copper

**Matériaux
Material**

Tous – All Laiton massif Solid Brass Diffuseur polycarbonate blanc White Polycarbonate diffuser	Suspension – Pendant Câble métallique et câble électrique transparent Metal cable and transparent electric cable <i>La longueur standard des câbles est de 2 mètres mais elle peut être diminuée à l'installation. The standard height of the cables is 2 meters (78.7") but can be adjusted to less during installation.</i>
--	---

**Source
Lamping**

Suspensions – Pendant lights						
Gamma L 5						
LED intégrée	580 lm	2700°K	8W	Alim. 24V int. dans le pavillon	Variable (phase cut)	
Integrated LED	580 lm	2700°K	8W	Int. power supply 24V incl. in canopy	Dimmable (phase cut)	
Gamma L 19						
LED intégrée	1730 lm	2700°K	22W	Alim. 24V int. dans le pavillon	Variable (phase cut)	
Integrated LED	1730 lm	2700°K	22W	Int. power supply 24V incl. in canopy	Dimmable (phase cut)	
Gamma R 40						
LED intégrée	3740 lm	2700°K	49W	Alim. 24V int. dans le pavillon	Variable (phase cut)	
Integrated LED	3740 lm	2700°K	49W	Int. power supply 24V incl. in canopy	Dimmable (phase cut)	
Gamma R 58						
LED intégrée	5180 lm	2700°K	65W	Alim. 24V int. dans le pavillon	Variable (phase cut)	
Integrated LED	5180 lm	2700°K	65W	Int. power supply 24V incl. in canopy	Dimmable (phase cut)	
Appliques – Wall lights						
Gamma XS						
LED intégrée	480 lm	2700°K	7W	Alimentation 24V int. intégrée	Variable (phase cut)	
Integrated LED	480 lm	2700°K	7W	Int. power supply 24V included	Dimmable (phase cut)	
Gamma XL						
LED intégrée	1820 lm	2700°K	20W	Alimentation 24V int. intégrée	Variable (phase cut)	
Integrated LED	1820 lm	2700°K	20W	Int. power supply 24V included	Dimmable (phase cut)	

Designer

Sylvain Willenz

Suspension – Pendant Gamma L 19

13 x Tubes laiton - 6 x Tubes diffuseurs
13 x Brass tubes - 6 x Diffuser tubes

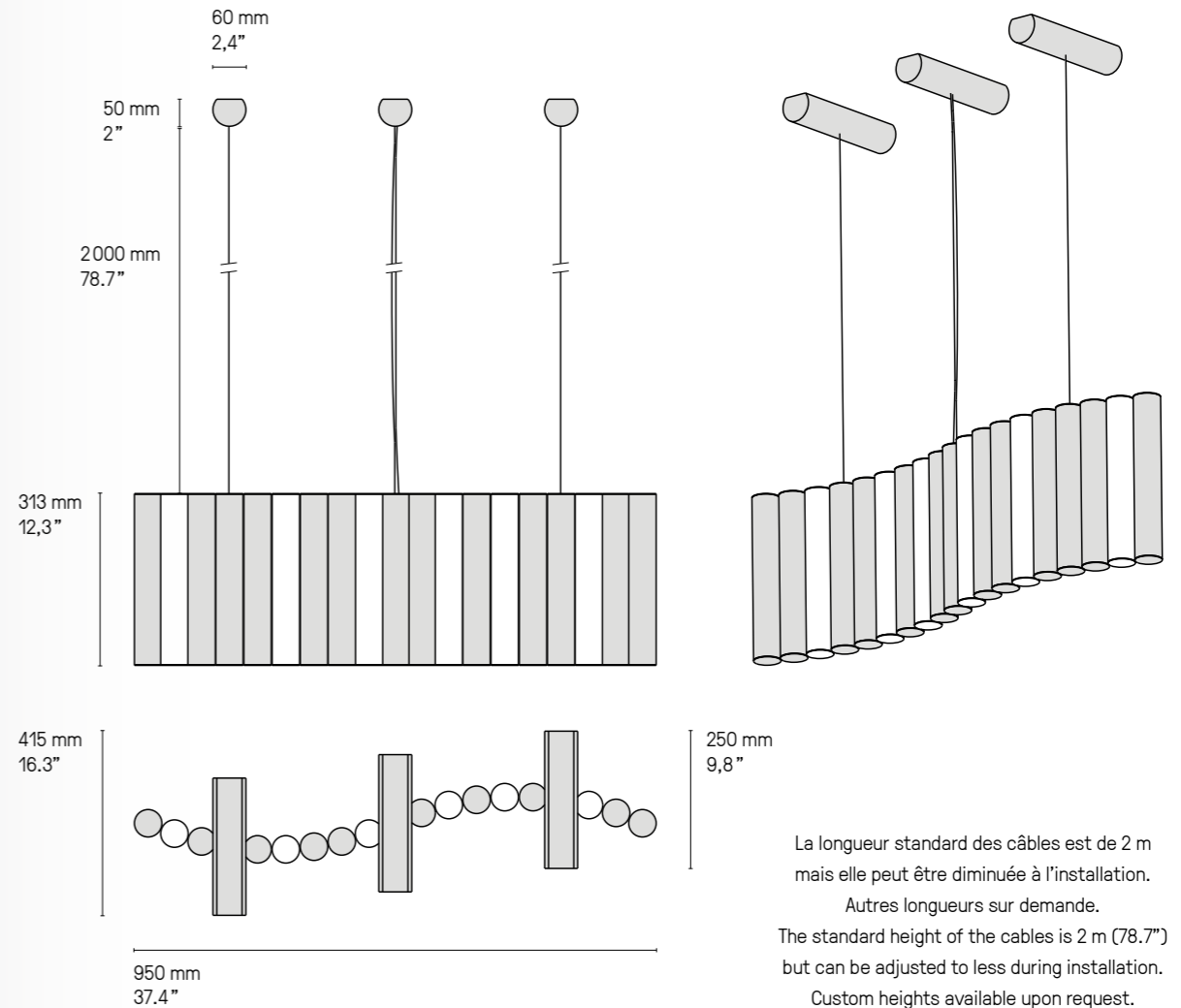

La longueur standard des câbles est de 2 m
mais elle peut être diminuée à l'installation.
Autres longueurs sur demande.
The standard height of the cables is 2 m (78.7")
but can be adjusted to less during installation.
Custom heights available upon request.



Gamma L 19 SB

Suspension – Pendant Gamma R 40

27 x Tubes laiton - 13 x Tubes diffuseurs
 27 x Brass tubes - 13 x Diffuser tubes

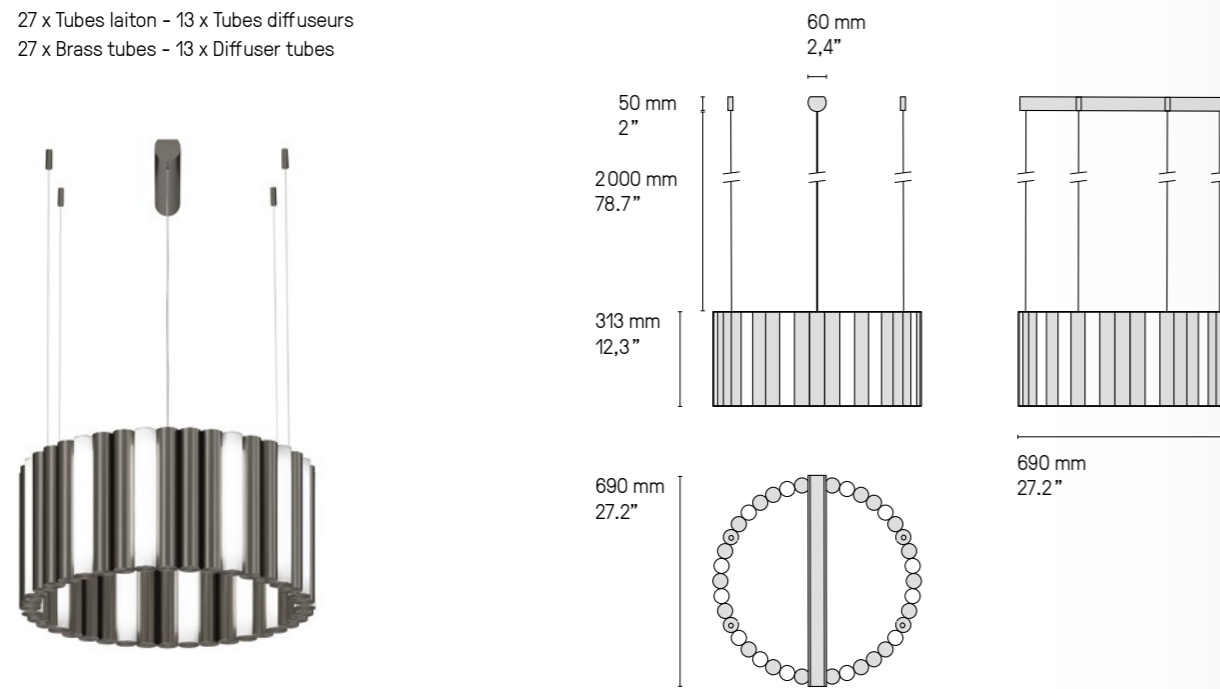

Suspension – Pendant Gamma R 58

40 x Tubes laiton - 18 x Tubes diffuseurs
 40 x Brass tubes - 18 x Diffuser tubes

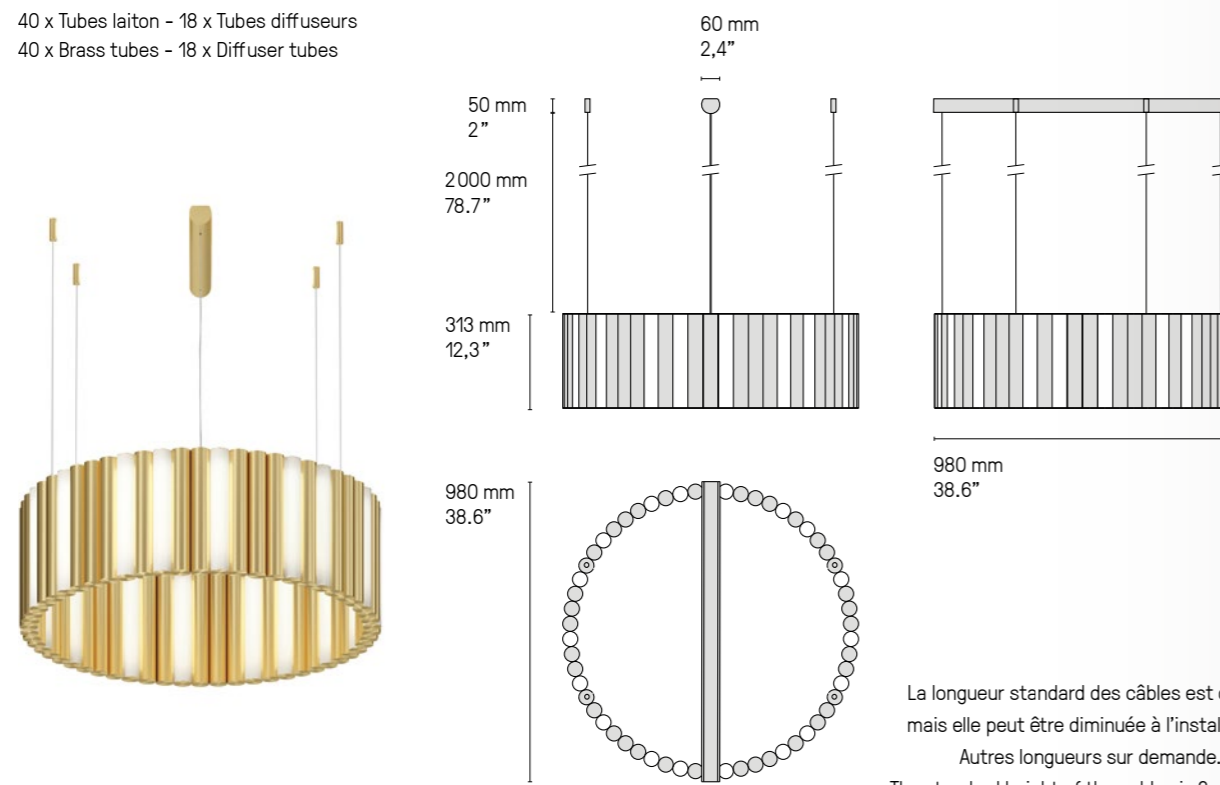

La longueur standard des câbles est de 2 m
 mais elle peut être diminuée à l'installation.
 Autres longueurs sur demande.
 The standard height of the cables is 2 m (78.7")
 but can be adjusted to less during installation.
 Custom heights available upon request.



Gamma R 40 SB

Suspension – Pendant Gamma L 5

3 x Tubes laiton - 2 x Tubes diffuseurs
 3 x Brass tubes - 2 x Diffuser tubes

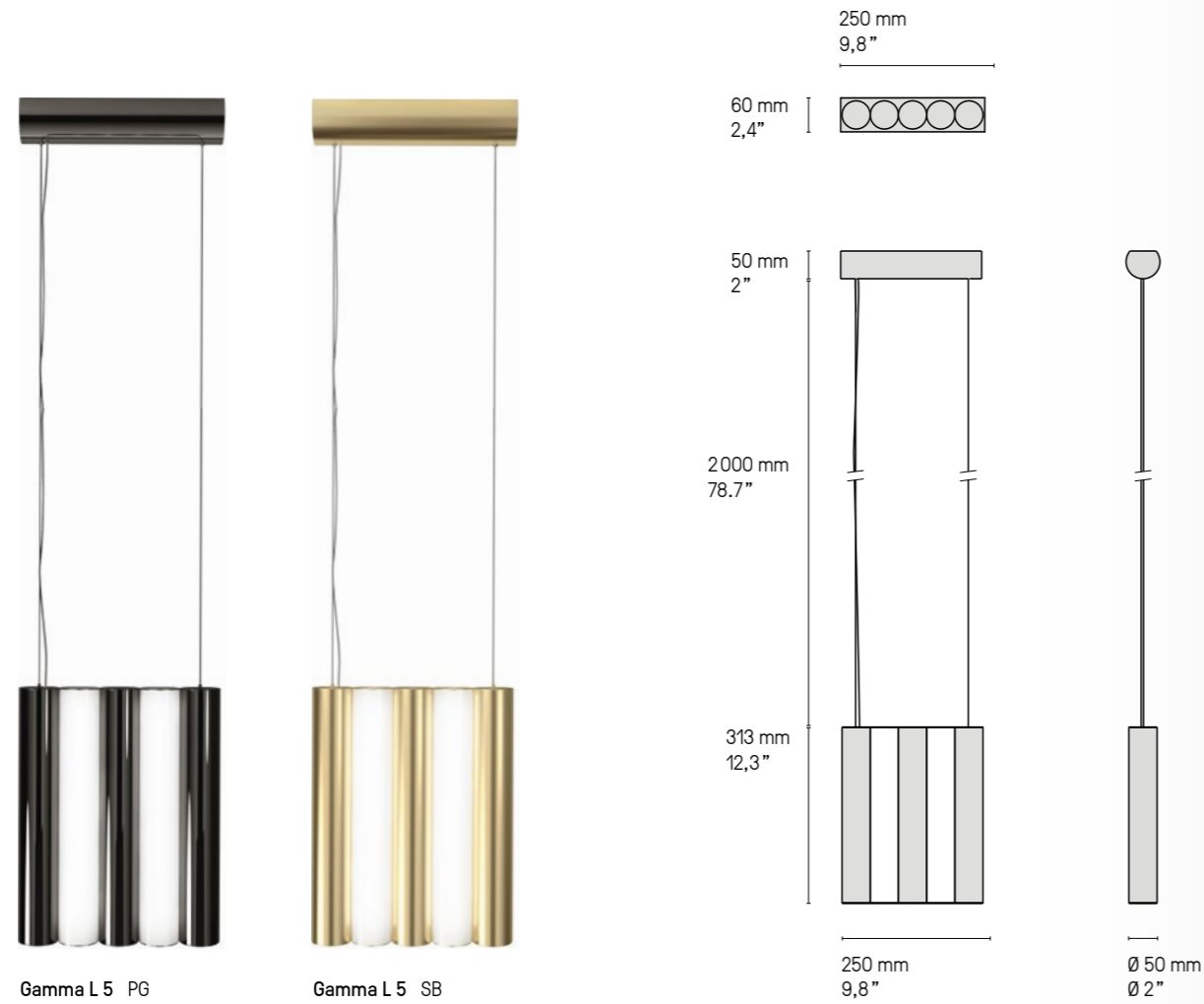

Gamma L 5 PG

Gamma L 5 SB

La longueur standard des câbles est de 2 m mais elle peut être diminuée à l'installation. Autres longueurs sur demande.
 The standard height of the cables is 2 m (78.7") but can be adjusted to less during installation. Custom heights available upon request.

Applique – Wall light Gamma XS

1 x Tube laiton - 2 x Tubes diffuseurs
 1 x Brass tube - 2 x Diffuser tubes



Gamma XS SB

Gamma XS SC



Gamma XS SN



Gamma XS SG

Retrouvez les variantes salle de bain (IP44) de ces modèles p.216
 You will find the bathroom variants (IP44) of these designs p.216

Applique – Wall light Gamma XL

2 x Tube laiton – 2 x Tubes diffuseurs
2 x Brass tube – 2 x Diffuser tubes

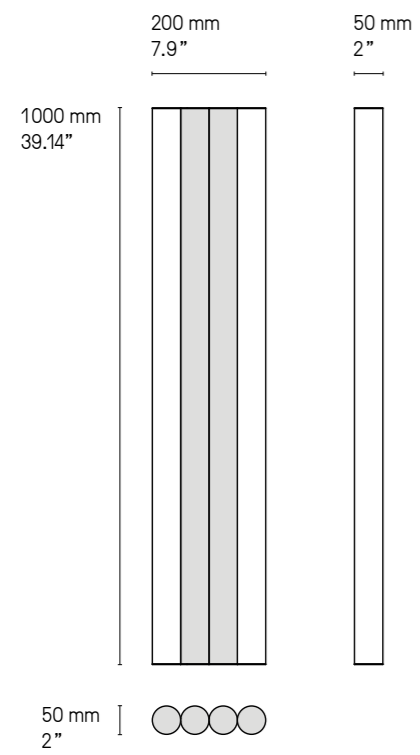

Gamma XL SG



Gamma XL SB



JANE D

Tel un petit phare de voiture ancienne, la coupelle de *Janed* vient refléter la lumière de la sphère opaline.



Like a small headlight from an old car, *Janed's* cup reflects the light of the opaline sphere

Finitions
Finishes ① + ②

Détails page 239

● Laiton satiné SB Satin brass	● Graphite satiné SG Satin graphite	● Nickel satiné SN Satin nickel	● Cuivre satiné SC Satin copper
● Laiton poli PB Polished brass	● Graphite poli PG Polished graphite	● Nickel poli PN Polished nickel	● Cuivre poli PC Polished copper

Matériaux Material	Tous – All Laiton massif Solid Brass	Tous – All Verre triplex opale Opal triplex glass	Janed 140 Cable Câble textile noir (longueur ≈ 2 m) Black textile cable (length ≈ 79")
-------------------------------------	---	--	---

Source
Lamping

Appliques – Wall mounted lights	
Janed 120 & 140 Simple G9 LED 5W max. non fournie G9 LED 5W max. not included	Variable* Dimmable*
Janed 140 Tirette/Cord G9 LED 5W max. non fournie G9 LED 5W max. not included	Interrupteur par tirette Pull cord switch
Janed 140 Cable G9 LED 5W max. non fournie G9 LED 5W max. not included	Interrupteur sur le câble Cable switch
Lampe de table – Table lamp	
Lampe de table – Table lamp G9 LED 5W max. non fournie G9 LED 5W max. not included	Interrupteur sur le câble Cable switch

Designer Émilie Cathelineau

* Les luminaires variables nécessitent l'utilisation d'ampoules compatibles avec la variation.
All dimmable light fixtures require the use of compatible bulbs.

US Version
fitted plate to cover
outlet power box

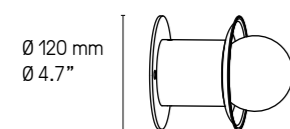

Applique – Wall mounted light
Janed 140 Simple SB



Applique – Wall mounted light
Janed 140 Simple SB/SG

Retrouvez les variantes salle de bain (IP44) de ces modèles p.218
You will find the bathroom variants (IP44) of these designs p.218

Janed Appliques – Wall lights

Janed 120 Simple

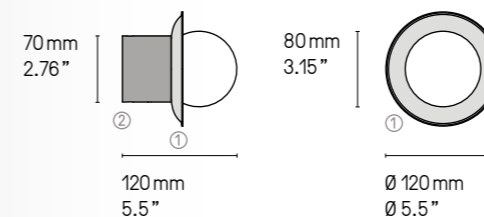

Janed 140 Simple

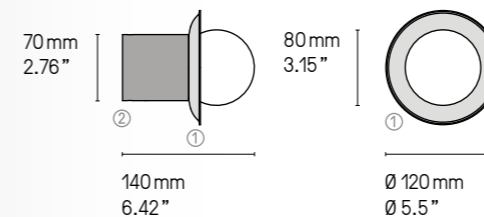

Janed 140 Tirette/Cord

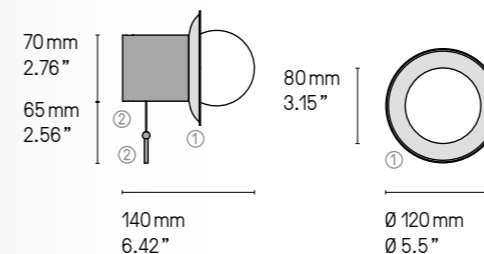

Janed 140 Cable

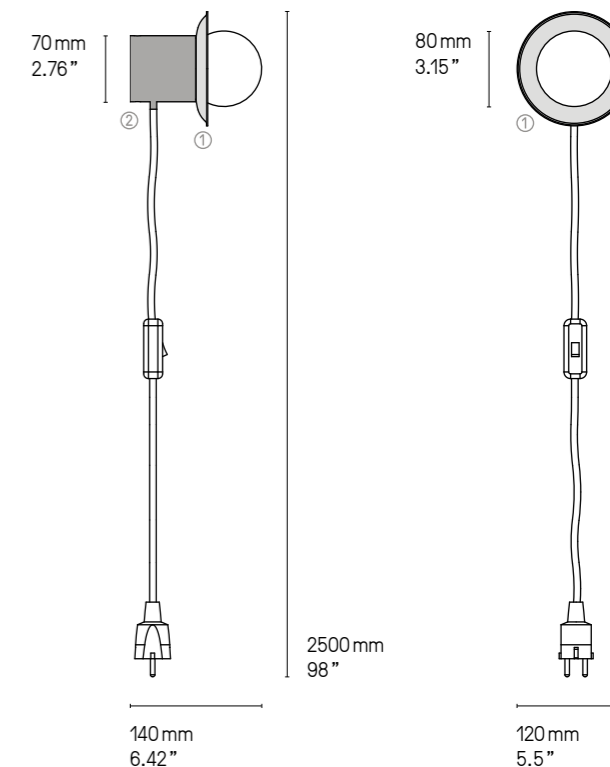

La longueur des câbles est réglable à l'installation.
The height of the cables can be adjusted during installation.



Applique – Wall mounted light Janed 140 Tirette/Cord SC/SG



Applique – Wall mounted light
Janed 140 Simple SN



Applique – Wall mounted light
Janed 140 Tirette – Cord SG



Applique – Wall mounted light
Janed 140 Cable PN

Longueur de câbles sur mesure possibles.
Custom cable dimensions upon request.



Appliques – Wall mounted lights Janed 120 Simple SG



Lampe de table – Table lamp Janed SB

Janed Lampe de table – Table lamp

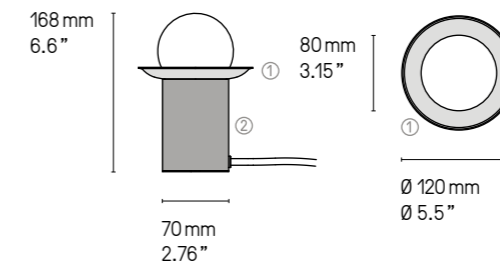

Lampe de table – Table lamp Janed SG



LINK









Sobre et minimaliste, la collection *Link* encadre la lumière. Selon l'orientation du luminaire, la ligne épurée s'inscrit dans l'espace vertical et horizontal.



Simple and minimalist, the *Link* collection frames the light. Depending on the position of the light, the refined line can be fitted vertically or horizontally.

Finitions
Finishes

Détails page 239











 Laiton satiné SB Satin brass	 Graphite satiné SG Satin graphite	 Nickel satiné SN Satin nickel	 Cuivre satiné SC Satin copper
 Laiton poli PB Polished brass	 Graphite poli PG Polished graphite	 Nickel poli PN Polished nickel	 Cuivre poli PC Polished copper

Matériaux
Material

Laiton massif Solid Brass	Diffuseur polycarbonate satiné Satin Polycarbonate diffuser	Lampadaire – Floor Lamp Câble textile noir (longueur ≈ 2 m) Black textile cable (length ≈ 78.7")
------------------------------	--	---

Source
Lamping

Appliques – Wall lights

Link 985 (985 mm – 38.8")						
LED intégrée	860 lm	2700°K	10W	Alim. électronique 24V int.	Variable (phase cut)	
Integrated LED	860 lm	2700°K	10W	Int. power supply 24V incl.	Dimmable (phase cut)	
 Integrated LED	860 lm	2700°K	10W	Int. power supply 24V incl.	Not dimmable	Damp
Link 725 (725 mm – 28.5")						
LED intégrée	620 lm	2700°K	8W	Alim. électronique 24V int.	Variable (phase cut)	
Integrated LED	620 lm	2700°K	8W	Int. power supply 24V incl.	Dimmable (phase cut)	
 Integrated LED	620 lm	2700°K	8W	Int. power supply 24V incl.	Not dimmable	Damp
Link 525 (525 mm – 20.7")						
LED intégrée	430 lm	2700°K	6W	Alim. électronique 24V int.	Variable (phase cut)	
Integrated LED	430 lm	2700°K	6W	Int. power supply 24V incl.	Dimmable (phase cut)	
 Integrated LED	430 lm	2700°K	6W	Int. power supply 24V incl.	Not dimmable	Damp
Link 375 (375 mm – 14.8")						
LED intégrée	290 lm	2700°K	5W	Alim. électronique 24V int.	Variable (phase cut)	
Integrated LED	290 lm	2700°K	5W	Int. power supply 24V incl.	Dimmable (phase cut)	
 Integrated LED	290 lm	2700°K	5W	Int. power supply 24V incl.	Not dimmable	Damp
Link 275 (275 mm – 10.8")						
LED intégrée	290 lm	2700°K	4W	Alim. électronique 24V int.	Variable (phase cut)	
Integrated LED	290 lm	2700°K	4W	Int. power supply 24V incl.	Dimmable (phase cut)	
 Integrated LED	290 lm	2700°K	4W	Int. power supply 24V incl.	Not dimmable	Damp
Liseuses murales – Reading wall lights						
Link 320 (320 mm – 12.7")						
LED intégrée	160 lm	2700°K	2W	Alimentation 24V int.	Non variable	
Integrated LED	160 lm	2700°K	2W	Int. power supply 24V incl.	Non dimmable	
 Integrated LED	100 lm	2700°K	2W	Int. power supply 24V incl.	Not dimmable	Damp
Link 410 (410 mm – 16.1")						
LED intégrée	250 lm	2700°K	4W	Alimentation 24V int.	Variable (phase cut)	Interrupteur intégré en option
Integrated LED	250 lm	2700°K	4W	Int. power supply 24V incl.	Dimmable (phase cut)	Integrated switch: optional
 Integrated LED	150 lm	2700°K	4W	Int. power supply 24V incl.	Not dimmable	Damp
Link 580 (580 mm – 22.8")						
LED intégrée	500 lm	2700°K	7W	Alimentation 24V int.	Variable (phase cut)	Interrupteur intégré en option
Integrated LED	500 lm	2700°K	7W	Int. power supply 24V incl.	Dimmable (phase cut)	Integrated switch: optional
 Integrated LED	290 lm	2700°K	7W	Int. power supply 24V incl.	Not dimmable	Damp
Link double 610 (610 mm – 24.1")						
LED intégrée	500 lm	2700°K	7W	Alimentation 24V int.	Variable (phase cut)	
Integrated LED	500 lm	2700°K	7W	Int. power supply 24V incl.	Dimmable (phase cut)	
 Integrated LED	290 lm	2700°K	7W	Int. power supply 24V incl.	Not dimmable	Damp
Link double 960 (960 mm – 37.8")						
LED intégrée	1010 lm	2700°K	12W	Alimentation 24V int.	Variable (phase cut)	
Integrated LED	1010 lm	2700°K	12W	Int. power supply 24V incl.	Dimmable (phase cut)	
 Integrated LED	580 lm	2700°K	12W	Int. power supply 24V incl.	Not dimmable	Damp
Link double 1300 (1300 mm – 51.2")						
LED intégrée	1350 lm	2700°K	17W	Alimentation 24V int.	Variable (phase cut)	2 interrupteurs int. en option
Integrated LED	1350 lm	2700°K	17W	Int. power supply 24V incl.	Dimmable (phase cut)	2 int. switches: optional
 Integrated LED	770 lm	2700°K	17W	Int. power supply 24V incl.	Not dimmable	Damp

Source
Lamping

Lampadaire – Floor lamp						
LED intégrée	1690 lm	2700°K	21W	Alimentation 24V int.		Variateur à pied
Integrated LED	1690 lm	2700°K	21W	Int. power supply 24V incl.		Foot operated dimmer
Lampe de table – Table lamp						
LED intégrée	240 lm	2700°K	5W	Alim. int. sur la prise		Interrupteur sur câble
Integrated LED	240 lm	2700°K	5W	Plug-in power supply		Cable switch

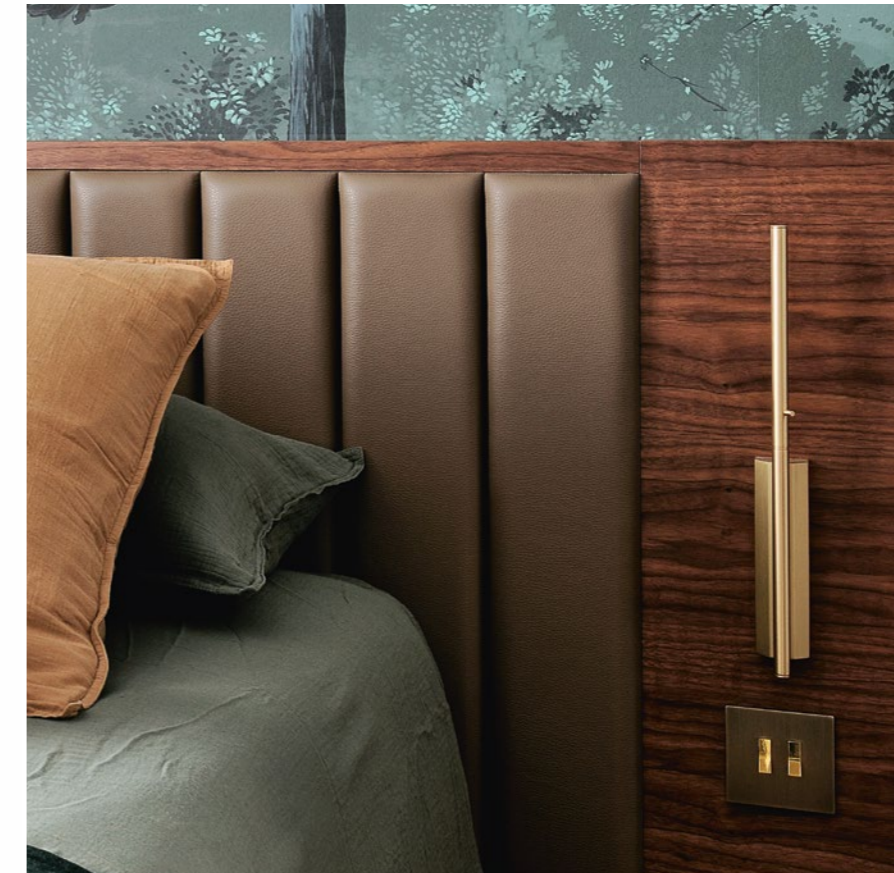

Liseuse murale – Reading wall light Link 410 SB



Appliques – Wall lights

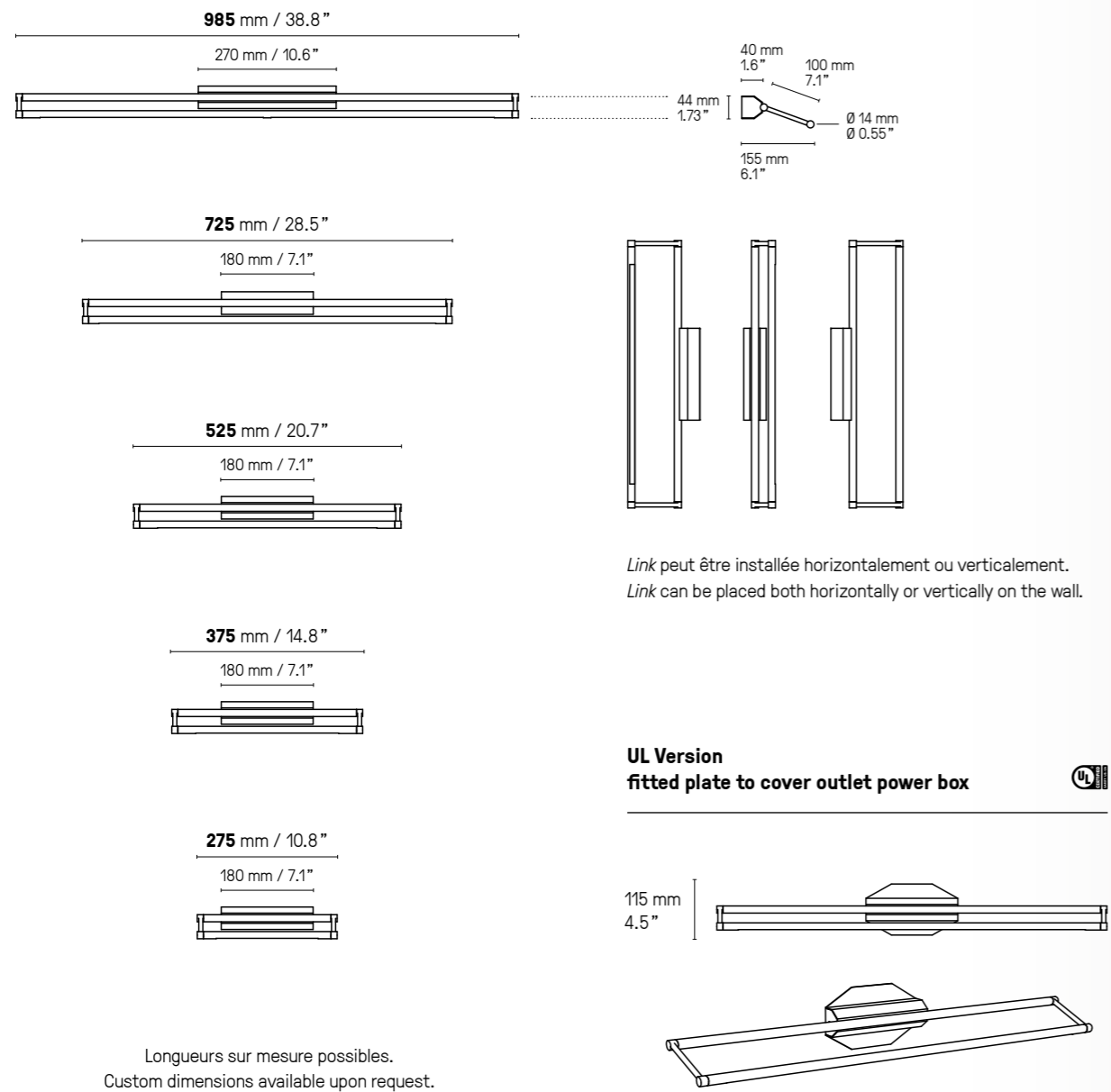

Description
Features

Cette applique est réglable sur 2 axes. Le tube avant, dans lequel se trouve la LED tourne afin de diriger la lumière dans n'importe quelle direction. L'ensemble formant un cadre peut également pivoter de haut en bas si l'applique est installée à l'horizontale, ou de gauche à droite si elle est installée à la verticale.

The wall light is adjustable in 2 ways. The front LED bar can be spinned around to diffuse the light in any direction and the rectangular frame can be flipped up and down when the light is positioned horizontally, and side to side when positioned vertically.



Applique – Wall light Link 985 SB

Liseuses murales – Reading wall lights

Longueurs sur mesure possibles
 Retrouvez les variantes salle de bain (IP44) de ces modèles p.220
 Custom dimensions available upon request
 You will find the bathroom variants (IP44) of these designs p.220

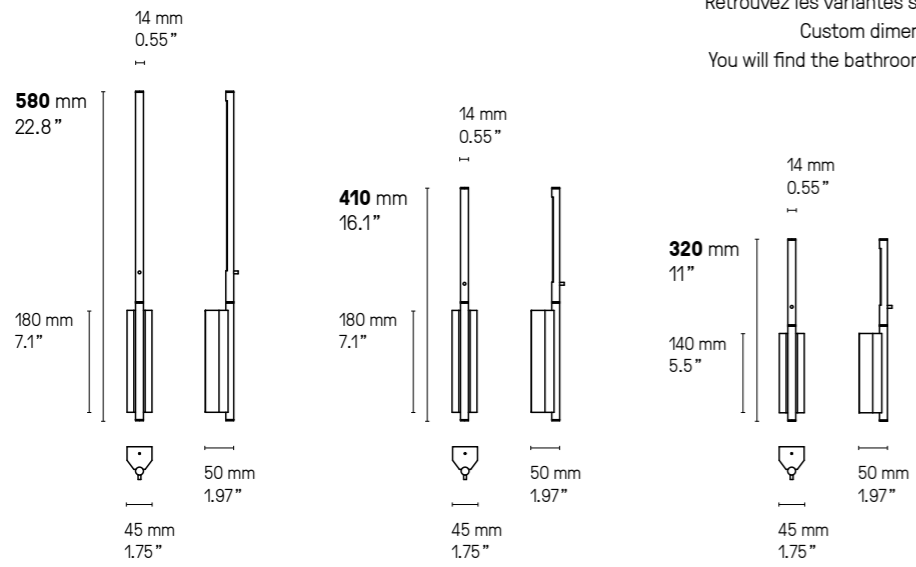

Interrupteur en option
 Switch in option

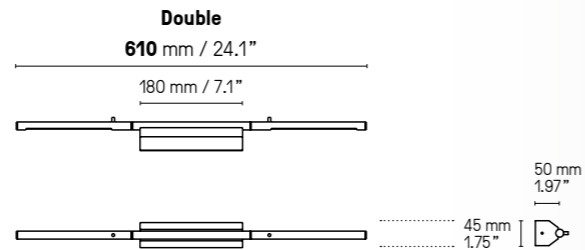
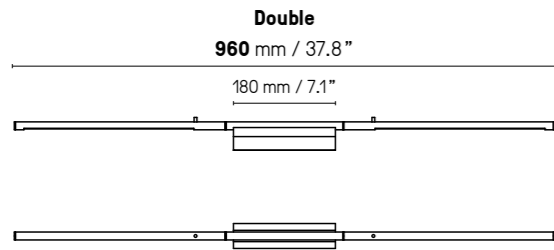
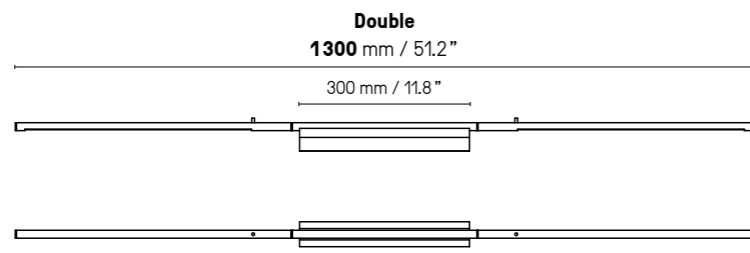

Retrouvez les variantes salle de bain (IP44) de ces modèles p.220
 You will find the bathroom variants (IP44) of these designs p.220



Le tube avant, dans lequel se trouve la LED, tourne afin de diriger la lumière dans n'importe quelle direction.
 The front LED bar can be spun around to diffuse the light in any direction.



**UL Version
 fitted plate
 to cover outlet
 power box**

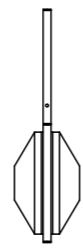

115 mm – 4.5"





Lampadaire – Floor lamp

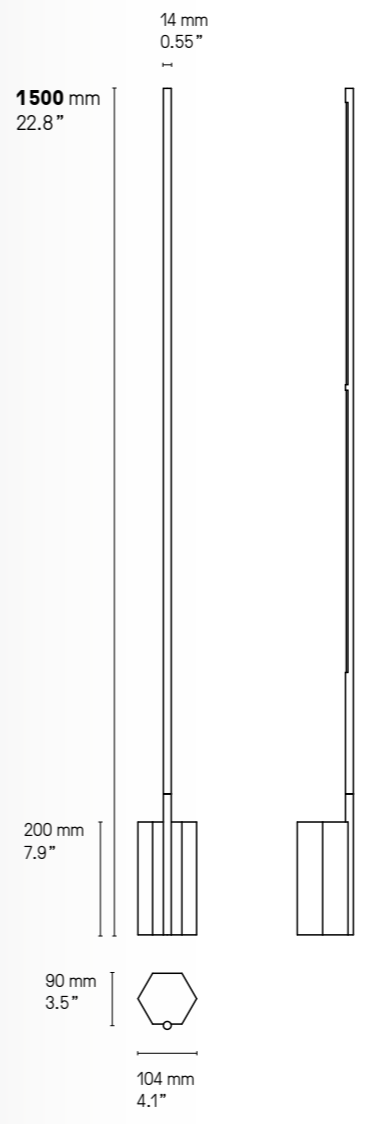

Lampadaire – Floor lamp Link SB

Lampe de table – Table lamp

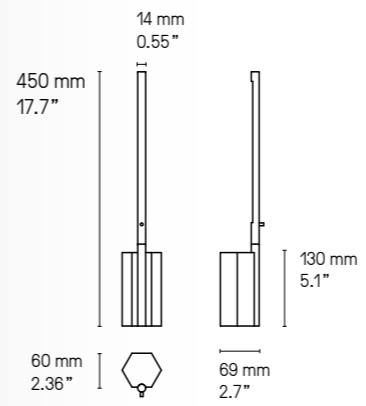

Lampe de table – Table lamp Link SB



LOUIS

Collection inspirée par le célèbre artiste de jazz, les suspensions *Louis* jouent des effets de lumières avec le verre et le laiton. Modulables, créez vos compositions de « trompettes » à l'envi.



A collection inspired by the iconic jazz artist, the *Louis* pendants play with lighting effects on the glass and the brass. Adjustable, you can arrange the “trumpets” as you wish.

Finitions
Finishes

- Laiton satiné / SB Satin brass
- Graphite satiné / SG Satin graphite
- Nickel satiné / SN Satin nickel
- Cuivre satiné / SC Satin copper

Détails page 239

Nuances du verre
Glass colors

- Opale et écaille / Opal and patterned
- Claire et écaille / Clear and patterned
- Opale (XS uniquement) / Opal (XS only)

Câble
Cable

- Tissu noir / Black textile
- Tissu or (sur demande uniquement) / Gold textile (on request only)

La longueur standard des câbles est de 2 mètres mais elle peut être diminuée à l'installation. The standard height of the cables is 2 meters (78.7") but can be adjusted to less during installation.

Matériaux
Material

- Laiton massif / Solid Brass
- Verrerie soufflée bouche / Mouth-blown glass
- Câble textile / Textile cable

Source
Lamping

LED intégrée	1500 lm	2700°K	14 W	Alim. électr. intégrée dans le pavillon	Variation (phase cut)
Integrated LED	1500 lm	2700°K	14 W	Int. power supply included in canopy	Dimmable (phase cut)
Integrated LED	1500 lm	2700°K	15 W	Int. power supply included in canopy	Not dimmable

Designer

Émilie Cathelineau

Louis XS

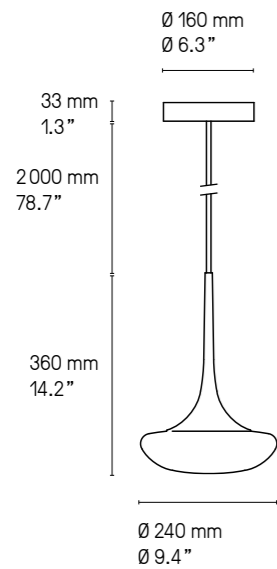

Louis XL

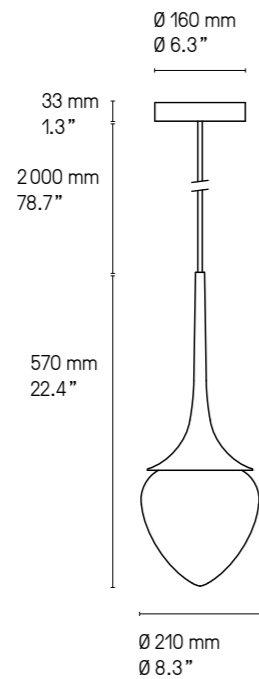

La longueur standard des câbles est de 2 m mais elle peut être diminuée à l'installation. Autres longueurs sur demande. The standard height of the cables is 2 m (78.7") but can be adjusted to less during installation. Custom heights available upon request.

500 mm
19.7"

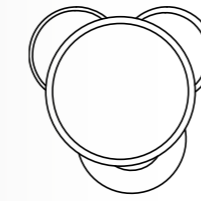

Ø 340 mm / 13.4"
Ø 300 mm / 11.8"

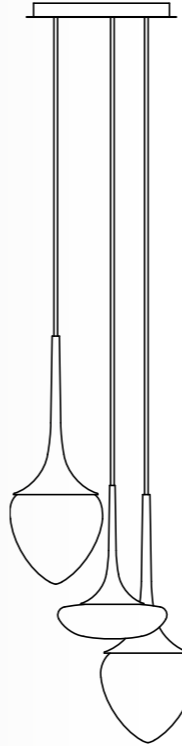

580 mm
22.8"

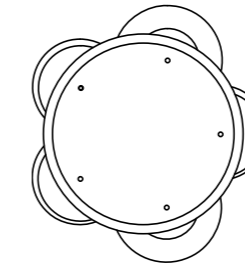

Ø 440 mm / 17.3"
Ø 400 mm / 15.7"

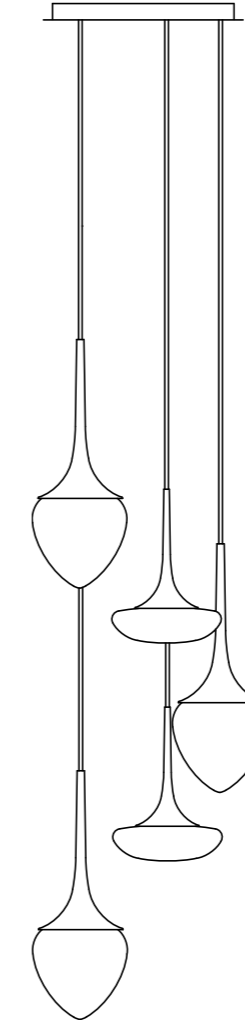

1100 mm
43.3"

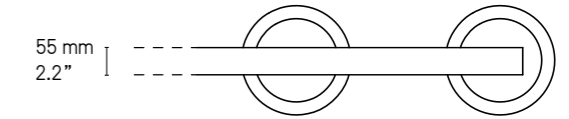

1000 mm / 39.4"

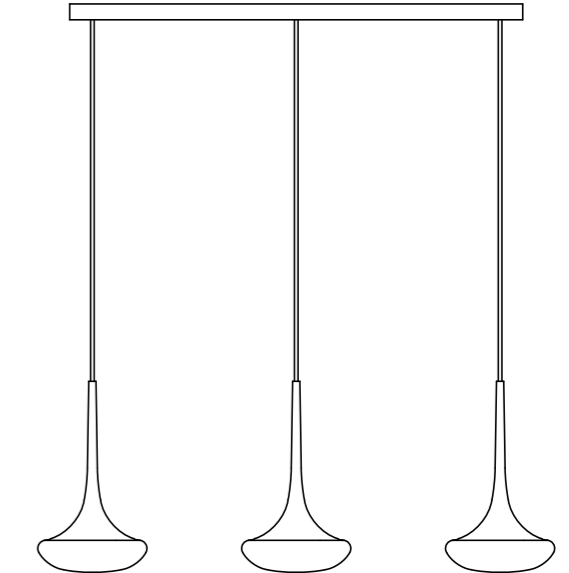

US Version
fitted plate to cover
outlet power box

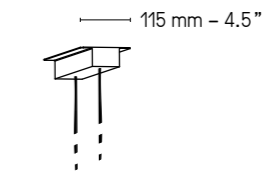

Il est possible de rassembler plusieurs suspensions sur un seul pavillon, circulaire ou rectangulaire. La version rectangulaire peut être adaptée à n'importe quelle longueur. La version circulaire a un diamètre maximum indiqué sur les croquis ci-dessus. Pour plus de renseignements, veuillez nous contacter.

It is possible to cluster several pendants from one single canopy, either rectangular or circular. The rectangular canopy can be custom-made into any size to suit your requirements. As for the circular canopy, available sizes are illustrated above. Please contact us for further information.



Louis XS SG Opale et écaille – Opal and patterned



Louis XL SB Opale et écaille – Opal and patterned

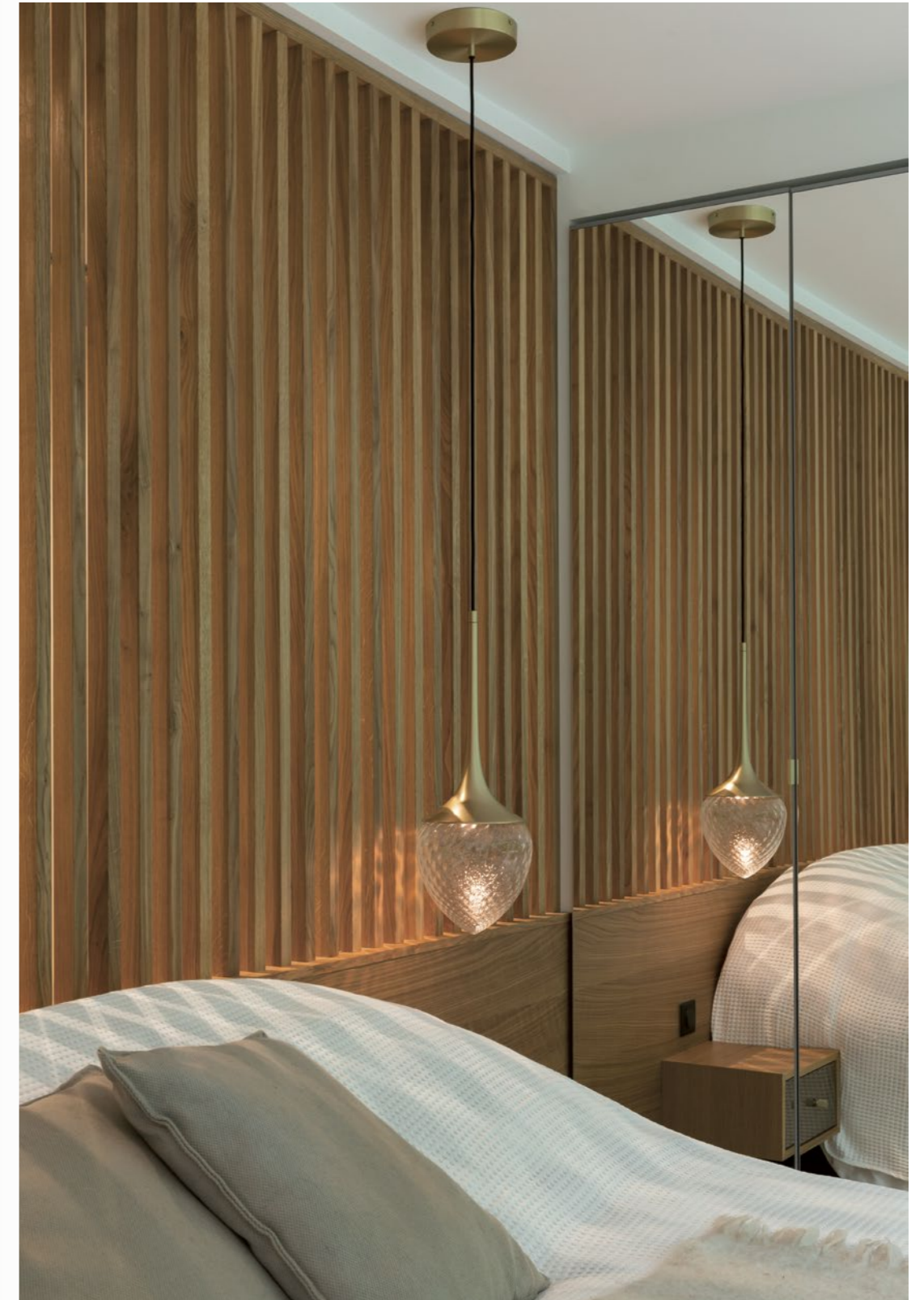

Louis XL SB Claire et écaille – Clear and patterned



NACHO

Inspiré de peintures, et tout droit sorti du langage graphique imaginaire de Sylvain Willenz, *Nacho* rassemble sur une même ligne divers éléments sculpturaux et lumineux.



Inspired by paintings, and straight out of the imaginary graphic language of Sylvain Willenz, *Nacho* gathers along one single line, various sculptural and lighting elements.

Finitions
Finishes ① + ② + ③

- Laiton satiné ● Graphite satiné ● Nickel satiné ● Cuivre satiné
- SB Satin brass SG Satin graphite SN Satin nickel SC Satin copper

Nuancier – Finish options

Matériaux
Material

Laiton massif Solid Brass	Verre opale Opal glass	Diffuseur polycarbonate satiné Satin Polycarbonate diffuser	Câble métallique gainé Sheathed metal cable
------------------------------	---------------------------	--	--

*La longueur standard des câbles est de 2 mètres
mais elle peut être diminuée à l'installation.
The standard height of the cables is 2 meters (78.7")
but can be adjusted to less during installation.*

Source
Lamping

Nacho 1300
Ruban LED intégré (840 lm, 2700°K, 26W) + Non incluses : G4 LED 3W max. et 2 x GU 5.3 LED 7W max.
Alimentations 24V et 12V intégrées dans le pavillon Variable (phase cut)
Integrated strip LED (840 lm, 2700°K, 26W) + Not included: G4 LED 3W max. and 2 x GU 5.3 LED 7W max.
Internal power supplies 24V and 12V included in canopy Dimmable (phase cut)

Nacho 750
Ruban LED intégré (670 lm, 2700°K, 20W) + Non incluses : 2 x G4 LED 3W max.
Alimentations 24V et 12V intégrées dans le pavillon Variable (phase cut)
Integrated strip LED (670 lm, 2700°K, 20W) + Not included: 2 x G4 LED 3W max.
Internal power supplies 24V and 12V included in canopy Dimmable (phase cut)

Designer Sylvain Willenz



Nacho 1300 SB/SB/SG

US Version
fitted plate to cover
outlet power box

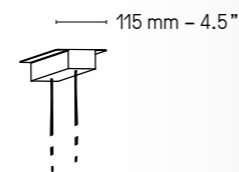

Nacho 750

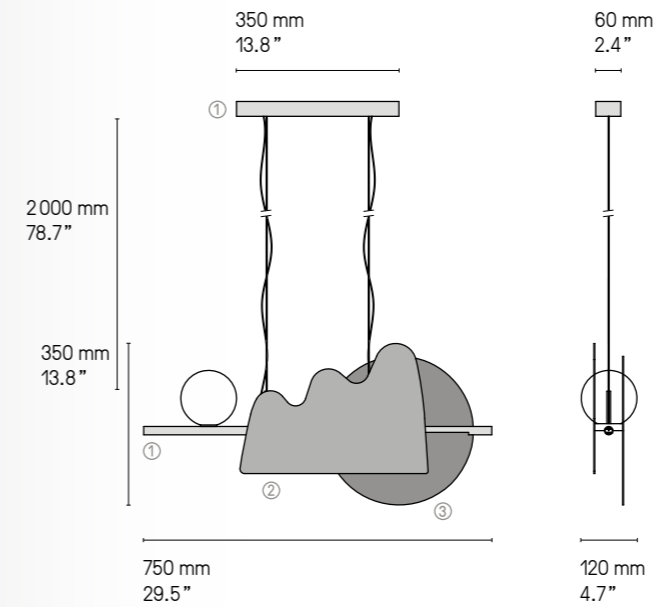

Nacho 750 SG/SG/SB

Nacho 1300

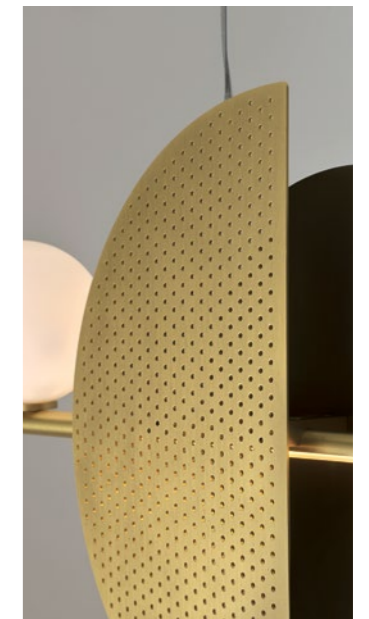
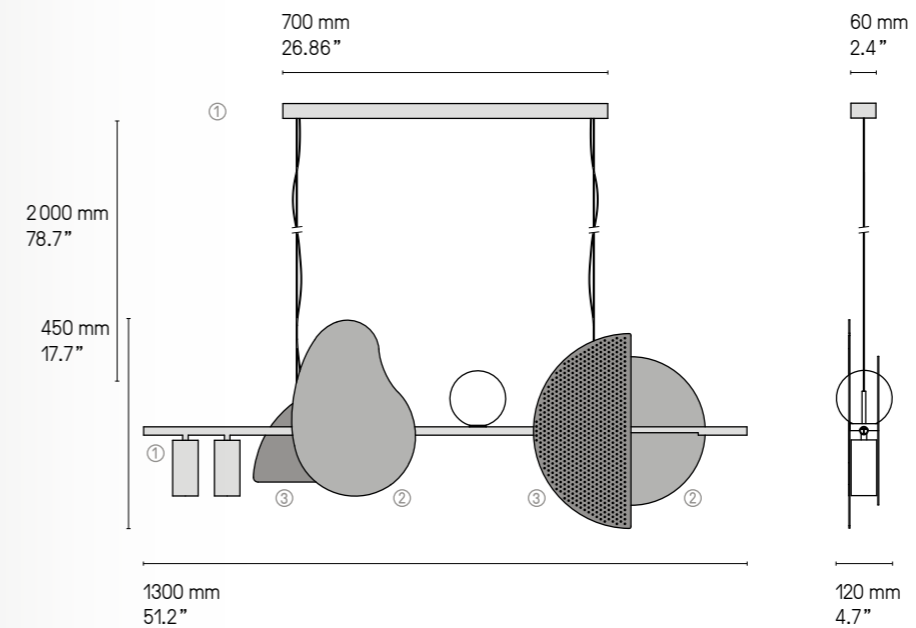

Nacho 1300 SB/SG/SB

La longueur standard des câbles est de 2 m mais elle peut être diminuée à l'installation. Autres longueurs sur demande.
The standard height of the cables is 2 m (78.7") but can be adjusted to less during installation. Custom heights available upon request.



PIROUETTE

Pirouette est une petite applique singulière, à la fois décorative et fonctionnelle. La rotation à 360° de son faisceau lumineux et sa variation tactile en font une applique de chevet idéale. Elle trouvera également sa place en répétition dans un couloir pour guider le passage.



Pirouette is a unique little wall lamp, both decorative and functional. The 360° rotation of its light beam and its touch-sensitive dimmer make it an ideal bedside wall lamp. Several positioned along a corridor will also provide useful lighting.

Finitions
Finishes ①+②

- Laiton satiné
SB Satin brass
- Graphite satiné
SG Satin graphite
- Nickel satiné
SN Satin nickel
- Cuivre satiné
SC Satin copper

Détails page 239

Matériaux
Material Laiton massif
Solid Brass

Source
Lamping Pirouette V1 & V2
LED intégrée 417 lm 2700°K 5W Alim. électronique 24V intégrée Variateur tactile
Integrated LED 417 lm 2700°K 5W Int. power supply 24V included Touch dimmer

Designer Émilie Cathelineau

US Version
fitted plate to cover
outlet power box

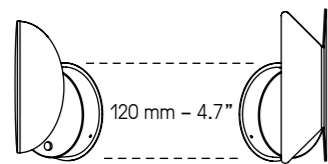

Variateur tactile – Touch dimmer



Pirouette V1 SB/SB



Pirouette V1 SG/SB

Pirouette V1

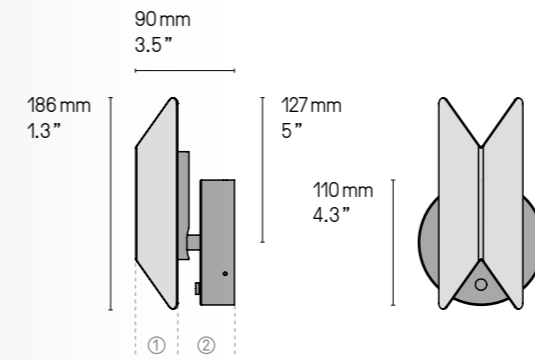

Pirouette V1 SG/SG

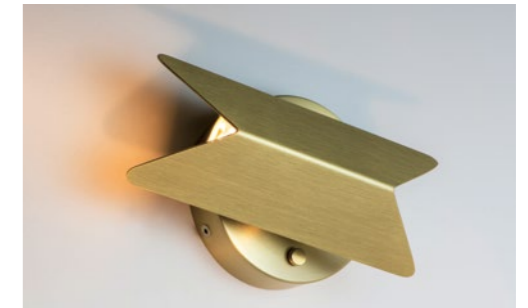
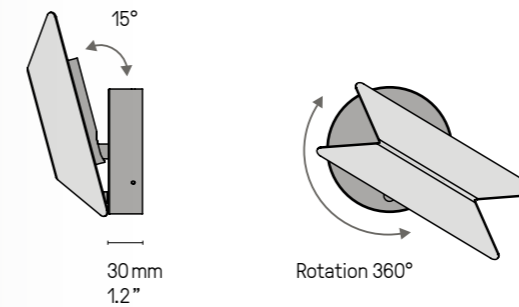

Pirouette V1 SB/SB

Pirouette V2

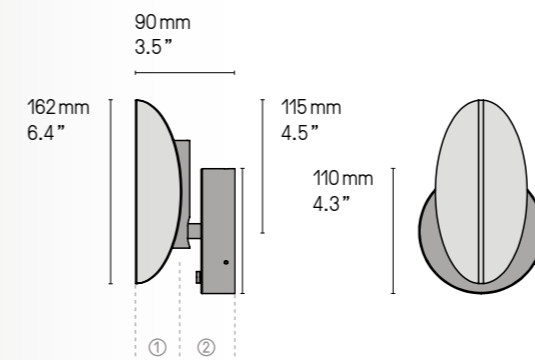

Pirouette V2 SG/SB

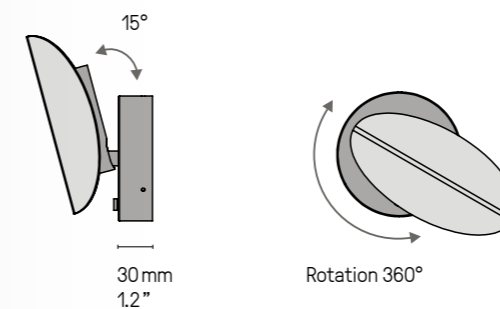

Pirouette V2 SB/SB



RING

À la fois inspirée des années 60 et intemporelle, la suspension bicolore *Ring* est montée d'une pièce « bijou » en laiton poli. Définissez ses tonalités selon l'effet décoratif recherché.



At once inspired by the 60's but also timeless, the two-toned pendant *Ring* is assembled with an imitated polished brass "jewel". Characterize its shades in accordance to the style you are looking for.

Finitions Finishes <small>Détails page 239</small>	Bicolore – Bicolor ①/②			
	● Graphite satiné SG / Laiton satiné SB Satin graphite / Satin brass	● Laiton satiné SB / Graphite satiné SG Satin brass / Satin graphite	● Graphite satiné SG / Nickel satiné SN Satin graphite / Satin nickel	● Nickel satiné SN / Graphite satiné SG Satin nickel / Satin graphite
Finitions Finishes	Uni – Unicolor			
	● Laiton satiné SB Satin brass	● Graphite satiné SG Satin graphite	● Nickel satiné SN Satin nickel	● Cuivre satiné SC Satin copper
Matériaux Material	Laiton massif Solid Brass	Diffuseur en polycarbonate Polycarbonate diffuser		
Description Features	Le modèle standard n'a pas de câble. Il est fixe sur un tube de 300 mm de long, ce qui donne une hauteur totale de 440 mm. Si vous souhaitez une hauteur supérieure à 440 mm, il est possible de réaliser une version « sur câble ». La longueur standard des câbles est de 2 mètres mais elle peut être diminuée à l'installation.			
	The standard <i>Ring</i> light does not come with a cable but only with a 300 mm (11,8") brass stem with a total drop of 440 mm (17,3"). For lengths over 440 mm (17,3") an adjustable transparent cable is added between the brass stem and the canopy in a standard length of 2 meters (78,7") and can be adjusted to less during installation.			
Source Lamping	2 modules de LEDs intégrées : 2 x 1000lm / 2700°K / 20W Diffusion de la lumière directe et indirecte	Alim. électronique intégrée dans le pavillon Variation (phase cut)		
	2 integrated LEDs : 2 x 1000lm / 2700°K / 20W Diffuses light from the top and the bottom	Integrated power supply in canopy Dimming (phase cut)		
	④ 2 integrated LEDs : 2 x 1900lm / 2700°K / 37W Diffuses light from the top and the bottom	Integrated power supply in canopy Dimming on request		
Designer	Émilie Cathelineau			



Ring SG/SB

Version fixe – Stem version

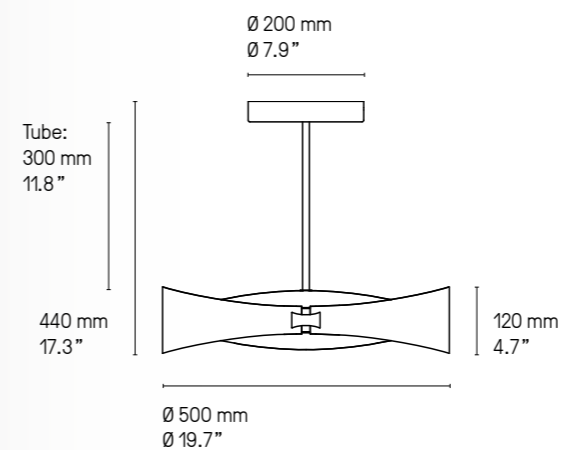

Version câble – Cable version

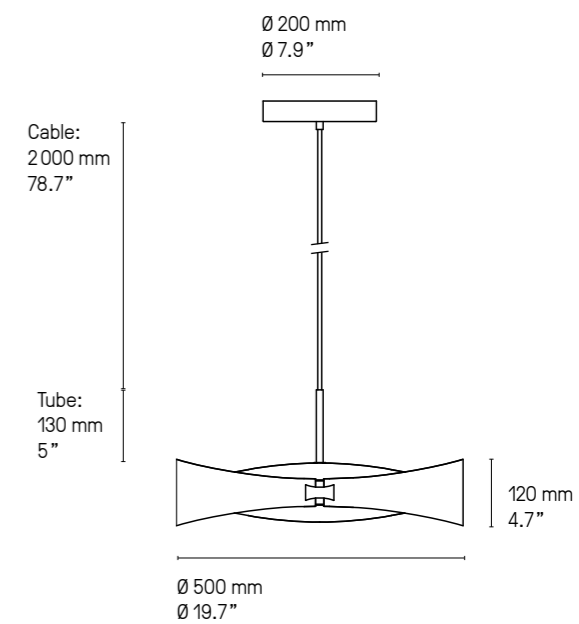

La longueur standard du câble est de 2 m mais elle peut être diminuée à l'installation. Autres longueurs sur demande.
The standard height of the cables is 2 m (78.7") but can be adjusted to less during installation. Custom heights available upon request.

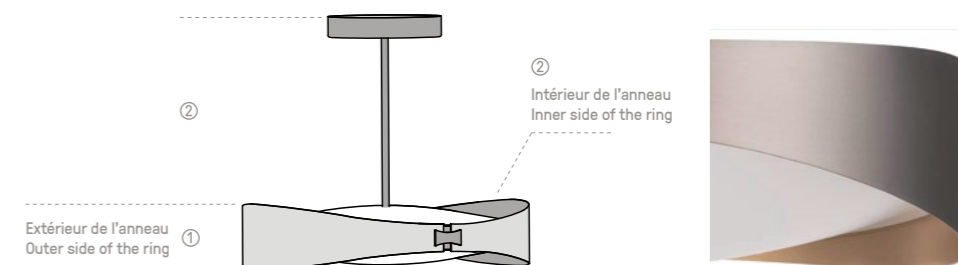

Ring SG/SB

En standard, les 2 « bijoux » sur le côté du produit sont en finition ② polie. Si vous préférez une finition satinée, merci de le préciser.

The 2 small brass parts on each side of the light always come in a polished ② finish but can be in satin if specified.





SATURNE

La sphère lumineuse est ici prétexte au voyage dans le système solaire. Munie d'un anneau en laiton orientable, la suspension *Saturne* devient le reflet de votre vision du cosmos.



For this particular light, the luminous sphere is a representation of the solar system. Provided with a rotating brass ring, the *Saturne* pendant becomes your vision of the cosmos.

Finitions	● Laiton satiné SB Satin brass	● Graphite satiné SG Satin graphite	● Nickel satiné SN Satin nickel	● Cuivre satiné SC Satin copper
<i>Détails page 239</i>				
Matériaux	Laiton massif Solid Brass	Verrerie opale soufflée bouche Opal mouth-blown glass	Câble textile (longueur ≈ 2 m) Textile cable (length ≈ 78.7")	
Câble	■ Tissu noir Black textile	■ Tissu or (sur demande uniquement) Gold textile (on request only)	<i>La longueur standard des câbles est de 2 mètres mais elle peut être diminuée à l'installation. The standard height of the cables is 2 meters (78.7") but can be adjusted to less during installation.</i>	
Source	XL	XS		
Lamping	LED intégrée 1500 lm 2700°K 14W	LED intégrée 800 lm 2700°K 8W	Alimentation int. dans le pavillon Int. power supply incl. in canopy	Variation (phase cut) Dimmable (phase cut)
	Integratred LED 1500 lm 2700°K 14W	Integratred LED 800 lm 2700°K 8W	Int. power supply incl. in canopy	Not dimmable
	Integratred LED 1500 lm 2700°K 14W			
			Alimentation int. dans le pavillon Int. power supply incl. in canopy	Variation (phase cut) Dimmable (phase cut), except for 110V
Designer	Hervé Langlais			

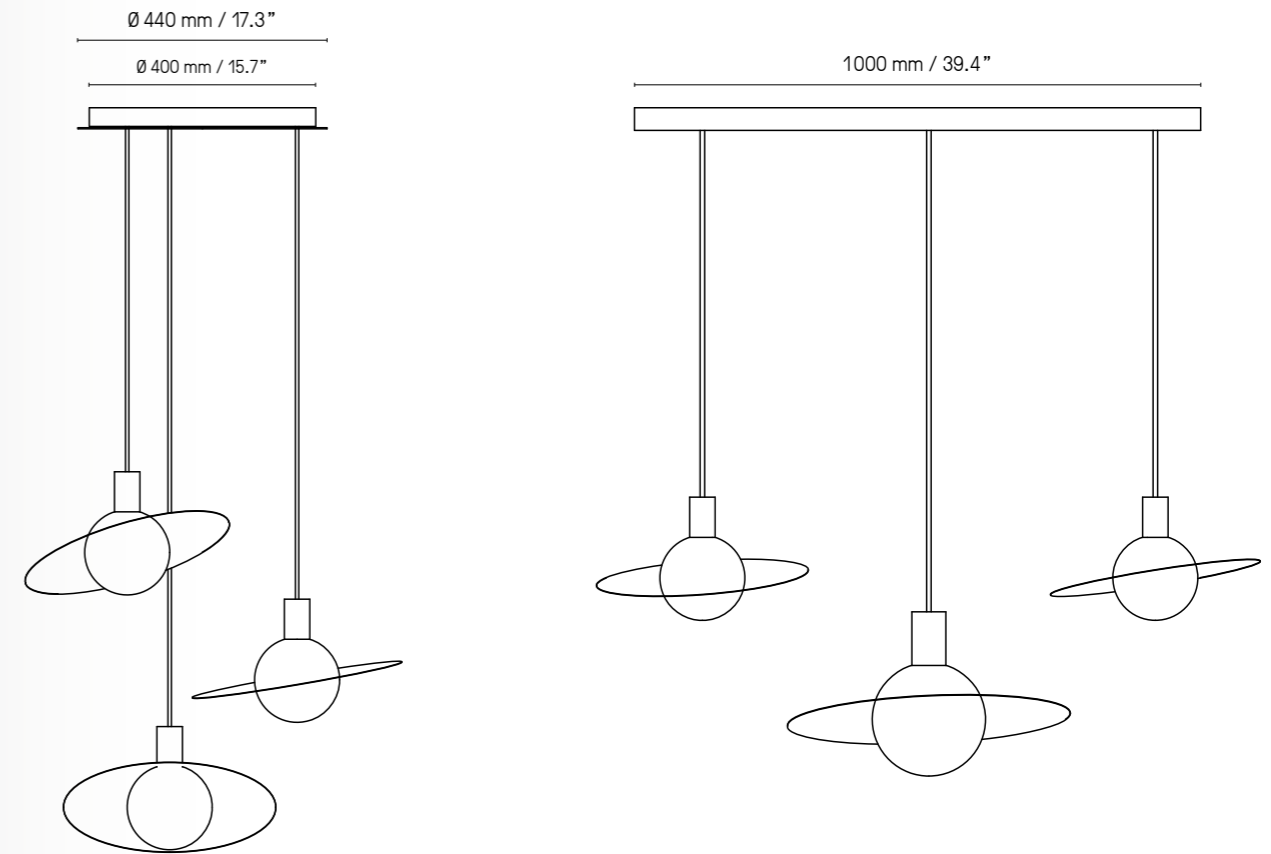

Saturne XL

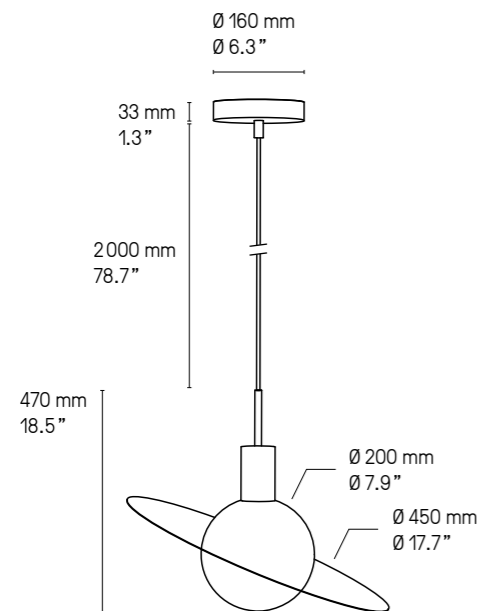

Saturne XS (not dimmable for 110V)

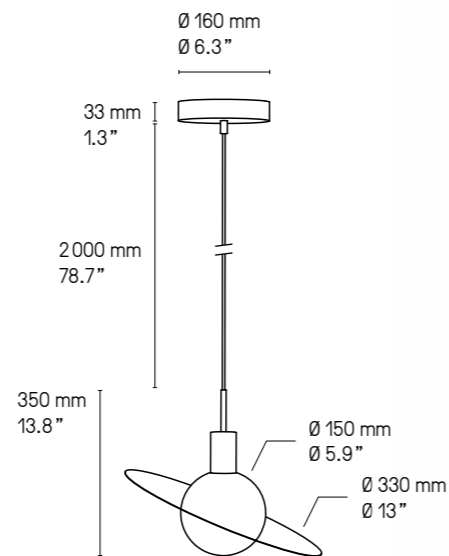

La longueur standard des câbles est de 2 m mais elle peut être diminuée à l'installation. Autres longueurs sur demande.
The standard height of the cables is 2 m (78.7") but can be adjusted to less during installation. Custom heights available upon request.



Saturne XL SB



Saturne XL & XS SB

Il est possible de rassembler plusieurs suspensions sur un seul pavillon, circulaire ou rectangulaire. La version rectangulaire peut être adaptée à n'importe quelle longueur. La version circulaire a un diamètre maximum indiqué sur les croquis ci-dessus. Pour plus de renseignements, veuillez nous contacter.

It is possible to cluster several pendants from one single canopy, either rectangular or circular. The rectangular canopy can be custom-made into any size to suit your requirements. As for the circular canopy, available sizes are illustrated above. Please contact us for further information.



SIGNAL

Apporter des lettres de noblesse au néon d'antan, voici l'esprit de la collection *Signal*. Véritable clin d'œil élégant, l'originalité de la source lumineuse désaxée se décline en appliques, suspensions et lampadaires.



Bringing something ancient back to fashion, this is what Pauline had in mind for the *Signal* collection. An elegant allusion, declined in wall lights, pendants and floor lamps, with their original asymmetric light source.

Finitions Finishes

Détails page 239

● Laiton satiné SB Satin brass	● Graphite satiné SG Satin graphite	● Nickel satiné SN Satin nickel	● Cuivre satiné SC Satin copper
● Laiton poli PB Polished brass	● Graphite poli PG Polished graphite	● Nickel poli PN Polished nickel	● Cuivre poli PC Polished copper

Matériaux Material

Laiton massif Solid Brass	Diffuseur polycarbonate satiné Satin Polycarbonate diffuser	Signal V 540, V 440, V 340 Câble textile noir (longueur ≈ 2 m) Black textile cable (length ≈ 78.7") Signal H 970, H 770 Câble métallique gainé (longueur ≈ 2 m) Sheathed metal cable (length ≈ 78.7")
------------------------------	--	--

La longueur standard des câbles est de 2 mètres
mais elle peut être diminuée à l'installation.
The standard height of the cables is 2 meters (78.7")
but can be adjusted to less during installation.

Source Lamping

Suspensions – Pendants

Signal H 970					
LED intégrée	1340 lm	2700°K	16 W	Alim. 24 V int. dans le pavillon	Variable (phase cut)
Integrated LED	1340 lm	2700°K	16 W	Int. power supply 24 V incl. in canopy	Dimmable (phase cut)
Signal H 770					
LED intégrée	960 lm	2700°K	12 W	Alim. 24 V int. dans le pavillon	Variable (phase cut)
Integrated LED	960 lm	2700°K	12 W	Int. power supply 24 V incl. in canopy	Dimmable (phase cut)
Signal V 540					
LED intégrée	770 lm	2700°K	10 W	Alim. 24 V int. dans le pavillon	Variable (phase cut)
Integrated LED	770 lm	2700°K	10 W	Int. power supply 24 V incl. in canopy	Dimmable (phase cut)
Signal V 440					
LED intégrée	580 lm	2700°K	8 W	Alim. 24 V int. dans le pavillon	Variable (phase cut)
Integrated LED	580 lm	2700°K	8 W	Int. power supply 24 V incl. in canopy	Dimmable (phase cut)
Signal V 340					
LED intégrée	380 lm	2700°K	7 W	Alim. 24 V int. dans le pavillon	Variable (phase cut)
Integrated LED	380 lm	2700°K	7 W	Int. power supply 24 V incl. in canopy	Dimmable (phase cut)

Appliques – Wall lights

Signal 345 (345 mm – 13.6")					
LED intégrée	280 lm	2700°K	5 W	Alimentation 24 V intégrée	Variable (phase cut)
Integrated LED	280 lm	2700°K	5 W	Int. power supply 24 V included	Dimmable (phase cut)
Integrated LED	280 lm	2700°K	5 W	Int. power supply 24 V included	Dimmable (phase cut)
Signal 445 (445 mm – 17.5")					
LED intégrée	480 lm	2700°K	7 W	Alimentation 24 V intégrée	Variable (phase cut)
Integrated LED	480 lm	2700°K	7 W	Int. power supply 24 V included	Dimmable (phase cut)
Integrated LED	480 lm	2700°K	7 W	Int. power supply 24 V included	Dimmable (phase cut)
Signal 545 (545 mm – 21.5")					
LED intégrée	670 lm	2700°K	9 W	Alimentation 24 V intégrée	Variable (phase cut)
Integrated LED	670 lm	2700°K	9 W	Int. power supply 24 V included	Dimmable (phase cut)
Integrated LED	670 lm	2700°K	9 W	Int. power supply 24 V included	Dimmable (phase cut)
Signal double 520 (520 mm – 20.5")					
LED intégrée	570 lm	2700°K	7 W	Alimentation 24 V intégrée	Variable (phase cut)
Integrated LED	570 lm	2700°K	7 W	Int. power supply 24 V included	Dimmable (phase cut)
Integrated LED	570 lm	2700°K	7 W	Int. power supply 24 V included	Dimmable (phase cut)
Signal double 720 (720 mm – 28.4")					
LED intégrée	960 lm	2700°K	13 W	Alimentation 24 V intégrée	Variable (phase cut)
Integrated LED	960 lm	2700°K	13 W	Int. power supply 24 V included	Dimmable (phase cut)
Integrated LED	960 lm	2700°K	13 W	Int. power supply 24 V included	Dimmable (phase cut)
Signal double 920 (920 mm – 36.2")					
LED intégrée	1340 lm	2700°K	17 W	Alimentation 24 V intégrée	Variable (phase cut)
Integrated LED	1340 lm	2700°K	17 W	Int. power supply 24 V included Int.	Dimmable (phase cut)
Integrated LED	1340 lm	2700°K	17 W	power supply 24 V included	Dimmable (phase cut)

Source Lamping

Lampadaires – Floor lamps

Lampadaire – Floor lamp DUO						
LED intégrée	2500 lm	2700°K	32 W	Alim. 24 V intégrée	Variable (phase cut)	Variateur à pied
Integrated LED	2500 lm	2700°K	32 W	Int. power supply 24 V incl.	Dimmable (phase cut)	Foot op. dimmer
Lampadaire – Floor lamp SOLO 115						
LED intégrée	1540 lm	2700°K	19 W	Alim. 24 V intégrée	Variable (phase cut)	Variateur à pied
Integrated LED	1540 lm	2700°K	19 W	Int. power supply 24 V incl.	Dimmable (phase cut)	Foot op. dimmer
Lampadaire – Floor lamp SOLO 176						
LED intégrée	1150 lm	2700°K	17 W	Alim. 24 V intégrée	Variable (phase cut)	Variateur à pied
Integrated LED	1150 lm	2700°K	17 W	Int. power supply 24 V incl.	Dimmable (phase cut)	Foot op. dimmer
Lampadaire – Floor lamp PIVOT						
LED intégrée	570 lm	2700°K	9 W	Alim. 24 V intégrée	Variable (phase cut)	Variateur à pied
Integrated LED	570 lm	2700°K	9 W	Int. power supply 24 V incl.	Dimmable (phase cut)	Foot op. dimmer

Designer

Pauline Deltour



Signal Pivot SB

Signal V 540

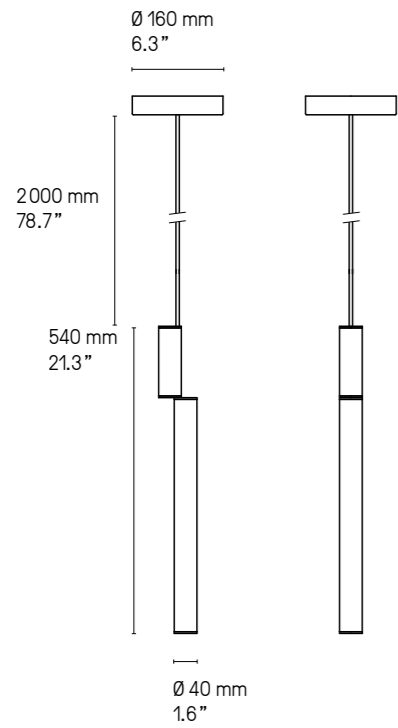

Signal V 540 + V440 SB

Signal V 440

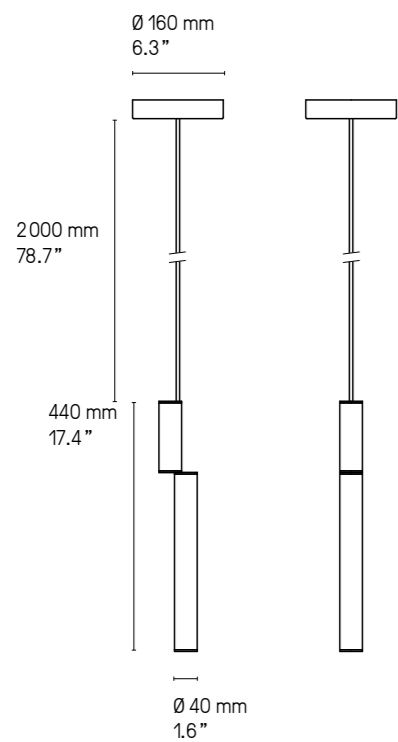

Signal V 340

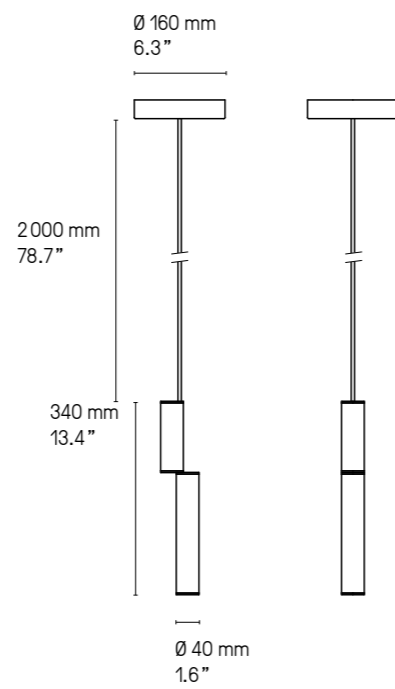

Signal H 970

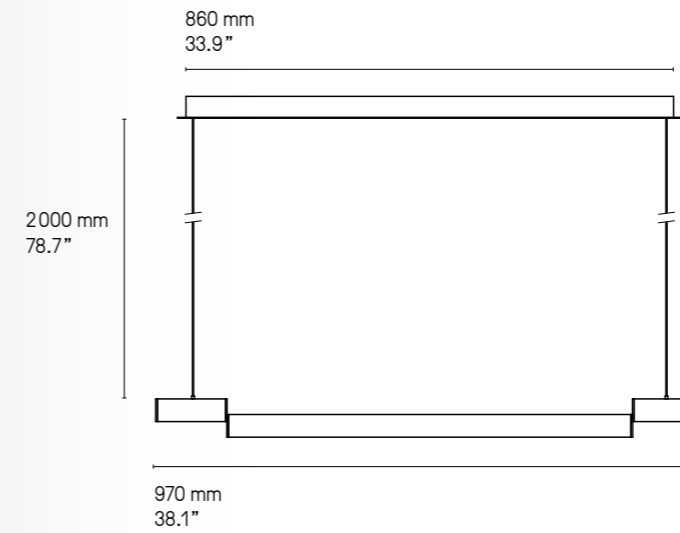

Signal H 770

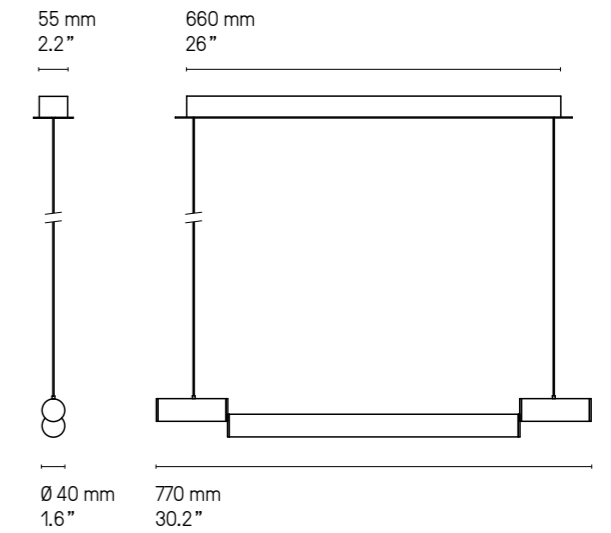

US Version
fitted plate to cover
outlet power box

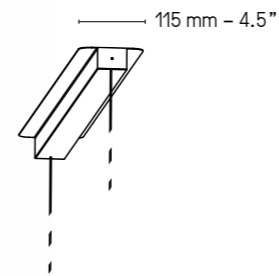

La longueur standard des câbles est de 2 m
mais elle peut être diminuée à l'installation.
Autres longueurs sur demande.
The standard height of the cables is 2 m (78.7")
but can be adjusted to less during installation
Custom heights available upon request.



Signal H 770 SB



Signal double 920

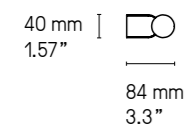
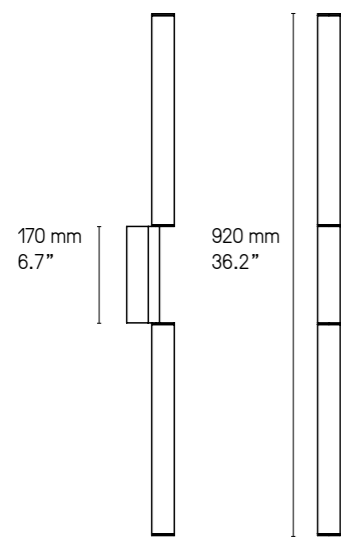

Signal double 720

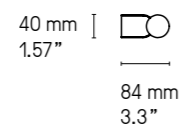
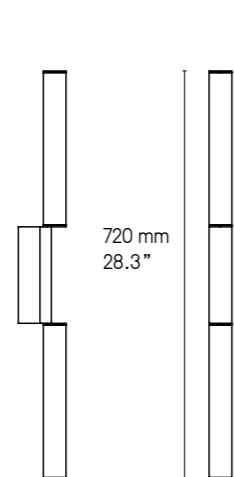

Signal double 520

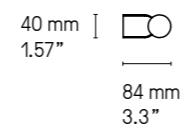
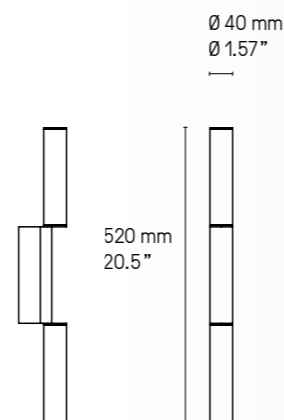

Signal simple 545

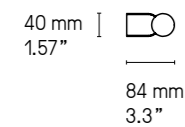
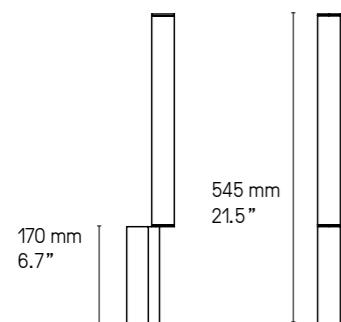

Signal simple 445

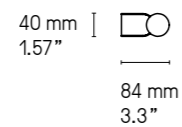
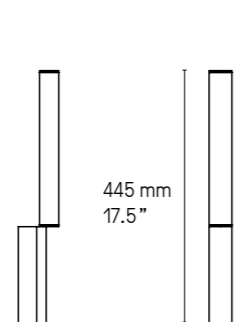

Signal simple 345

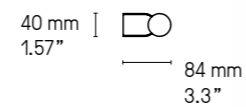
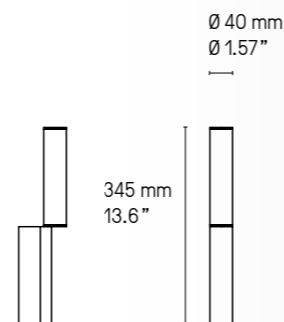

UL Version
fitted plate to cover outlet power box

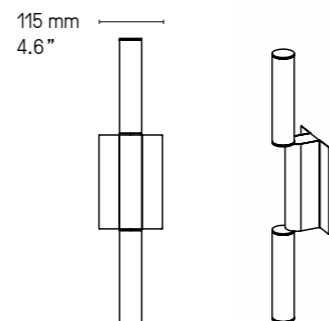

Signal peut être installée horizontalement ou verticalement.
Signal can be placed both horizontally or vertically on the wall.

Retrouvez les variantes salle de bain (IP44) de ces modèles p.228
You will find the bathroom variants (IP44) of these designs p.228

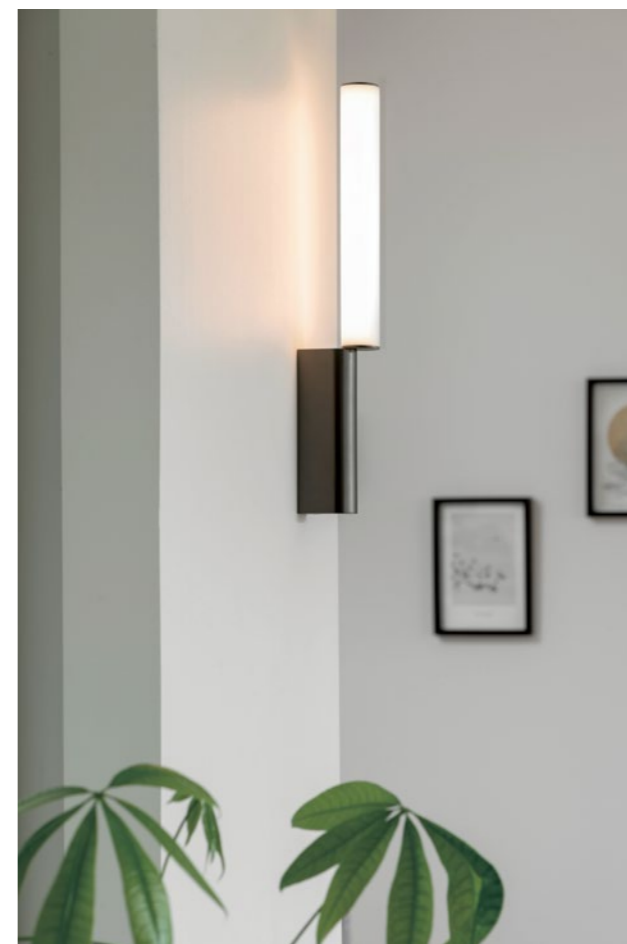

Signal Simple 445 SG

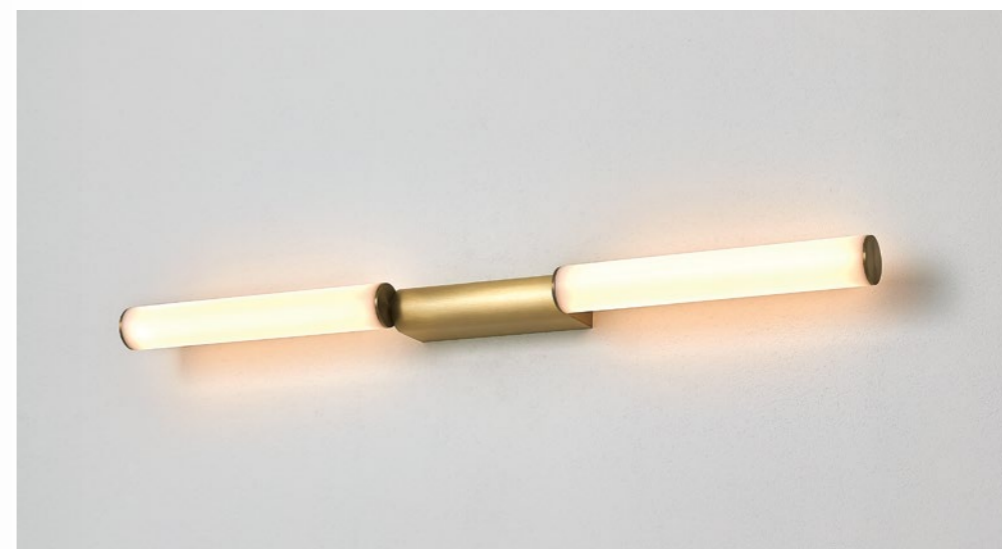

Signal Double 720 SB

Signal Duo

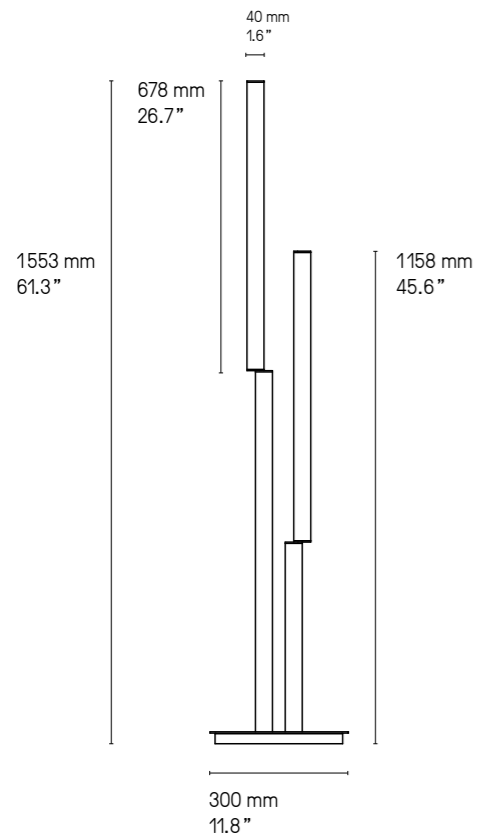

Signal Duo SB

Signal Pivot

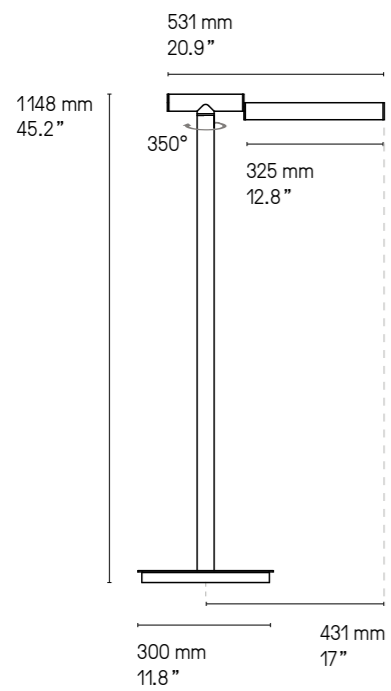

Signal Pivot SB

Signal Solo 176

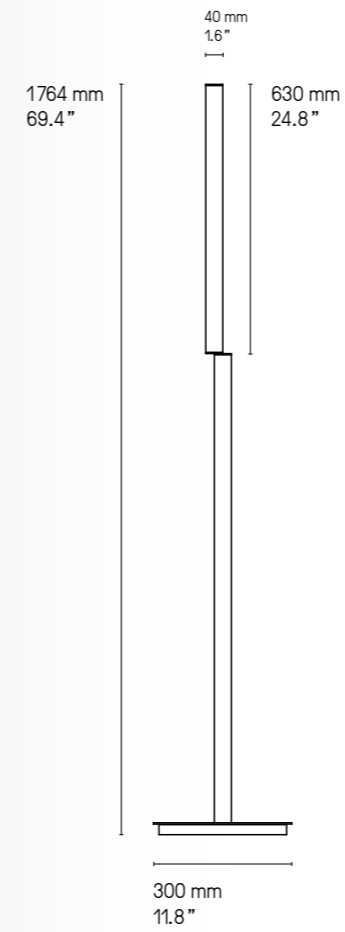

Signal Solo 176 SN

Signal Solo 115

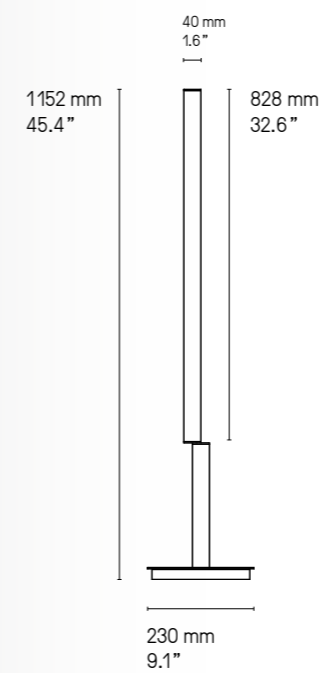

Signal Solo 115 SG



SOLITAIRE

Ce lampadaire trépied, rehaussé d'un abat-jour à facettes, courtise le bicolore. Personnalisable à souhait, cette pièce unique s'approprie avec élégance vos choix de finitions.



This three-legged floor lamp, enhanced by a faceted lampshade, is even more flattering in a two-tone finish. This unique piece, which can be customized, elegantly blends together with your choice of finishes.

Finitions
Finishes ①+②

Détails page 239

● Laiton satiné SB Satin brass	● Graphite satiné SG Satin graphite	● Nickel satiné SN Satin nickel	● Cuivre satiné SC Satin copper
● Laiton poli PB Polished brass	● Graphite poli PG Polished graphite	● Nickel poli PN Polished nickel	● Cuivre poli PC Polished copper

Abat-jour
Lampshade

■ Chinette noire Black chinette	□ Chinette blanche White chinette
------------------------------------	--------------------------------------

Matériaux
Material

Laiton massif Solid Brass	Abat-jour tissu Textile lampshade	Câble textile noir (longueur ≈ 1.5 m) Black textile cable (length ≈ 59")
------------------------------	--------------------------------------	---

Source
Lamping

1 x E27 LED 20W max. non fournie 1 x E27 LED 20W max. not included	Variateur à pied Foot operated dimmer	Variation* Dimming*
1 x E26 type A 150W. Bulb not included	Foot operated switch	

Designer

Émilie Cathelineau

* Les luminaires variables nécessitent l'utilisation d'ampoules compatibles avec la variation.
All dimmable light fixtures require the use of compatible bulbs.

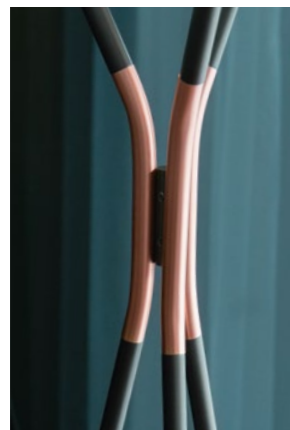

Solitaire XS SB/PB

Solitaire XL SG/SC

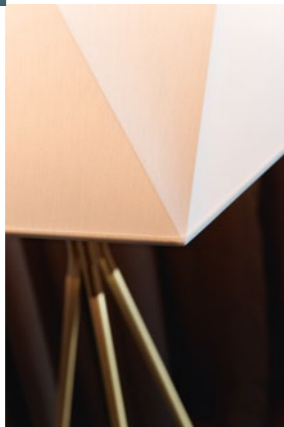

Solitaire XL

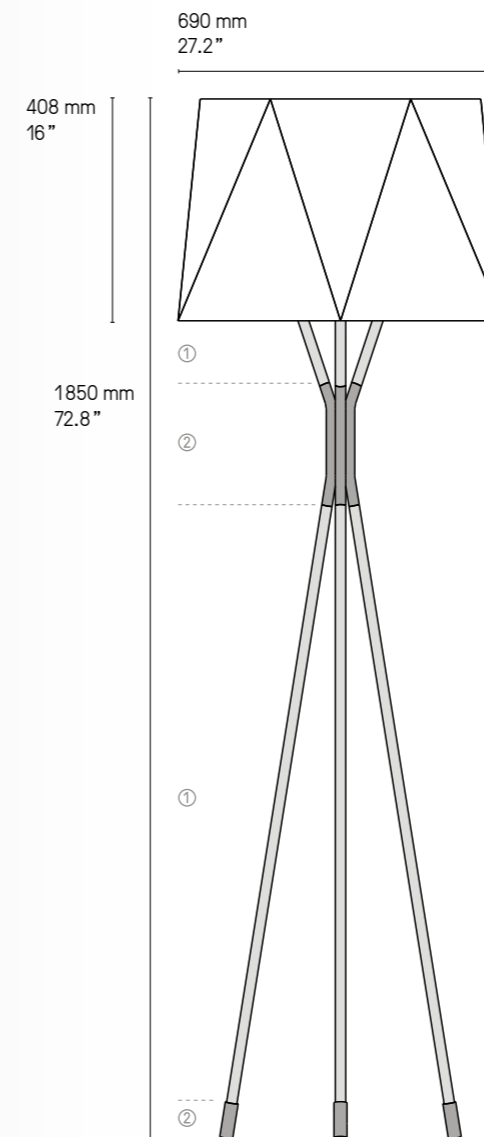
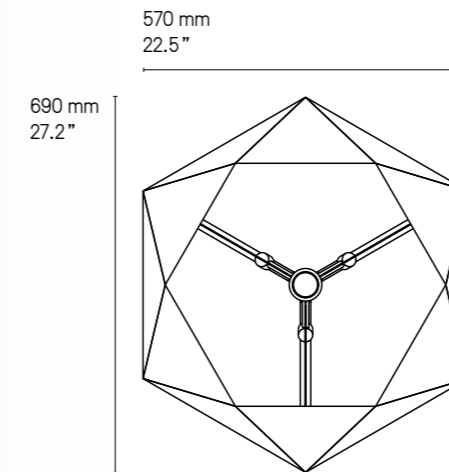

Solitaire XS

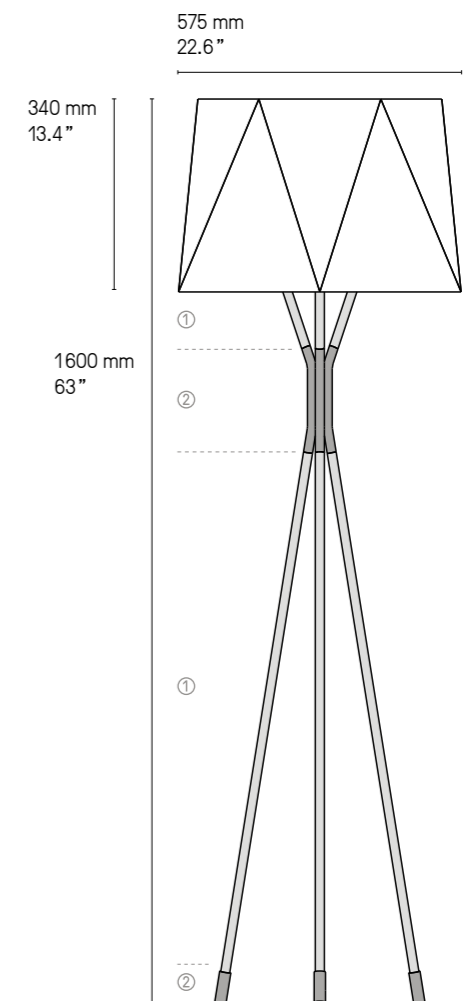
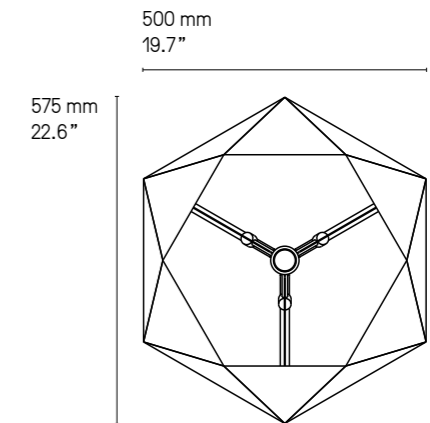

Version LED et DALI sur demande.
LED and DALI version upon request.



STORM

Lumière dirigée pour cette réinterprétation de la lampe tempête. La suspension et la lampe *Storm* affichent des lignes épurées, en toute intimité.



A reinterpretation of a storm made by light. The *Storm* pendant and lamp show off delicate and refined lines.

Finitions Finishes	● Laiton satiné	● Graphite satiné	● Nickel satiné	● Cuivre satiné
	SB Satin brass	SG Satin graphite	SN Satin nickel	SC Satin copper
<i>Détails page 239</i>				
	● Laiton poli	● Graphite poli	● Nickel poli	● Cuivre poli
	PB Polished brass	PG Polished graphite	PN Polished nickel	PC Polished copper

Matériaux Material	Tous – All	Tous sauf suspension – All except pendant	Suspension – Pendant
	Laiton massif Solid Brass	Diffuseur polycarbonate blanc White Polycarbonate diff user	Câble métallique gainé Sheathed metal cable
<i>La longueur standard des câbles est de 2 mètres mais elle peut être diminuée à l'installation. The standard height of the cables is 2 meters (78.7") but can be adjusted to less during installation.</i>			

Source Lamping	Suspension – Pendant				
	LED intégrée	550 lm	2700°K	8W	Alimentation intégrée dans le pavillon
	Integrated LED	550 lm	2700°K	8W	Int. power supply included in canopy
					Variable (phase cut)
					Dimmable (phase cut)
	Applique – Wall lamp				
	LED intégrée	480 lm	2700°K	7W	Alim. intégrée
	Integrated LED	480 lm	2700°K	7W	Internal power supply
	Lampe de table – Table lamp				
	LED intégrée	480 lm	2700°K	5W	Alim. intégrée sur la prise
	Integrated LED	480 lm	2700°K	5W	Plug-in power supply
	Lampadaire – Floor lamp				
	LED intégrée	1440 lm	2700°K	10W	Alim. intégrée sur la prise
	Integrated LED	1440 lm	2700°K	10W	Plug-in power supply

Designer Émilie Cathelineau

Lampe de table – Table lamp

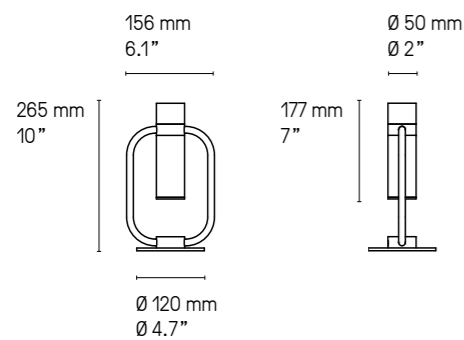

Lampe de table – Table lamp
Storm SG

Applique – Wall light

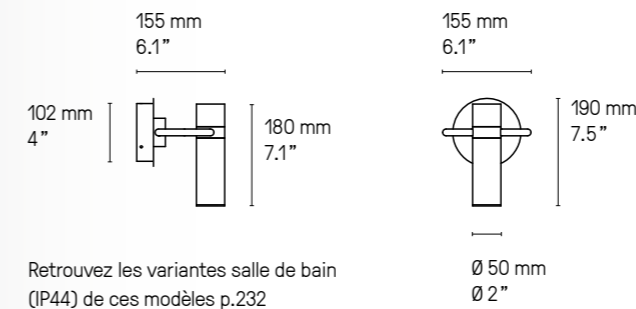

US Version
fitted plate to cover
outlet power box

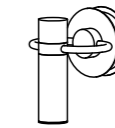

Applique – Wall light
Storm SB

Retrouvez les variantes salle de bain (IP44) de ces modèles p.232
You will find the bathroom variants (IP44) of these designs p.232

Lampadaire – Floor lamp

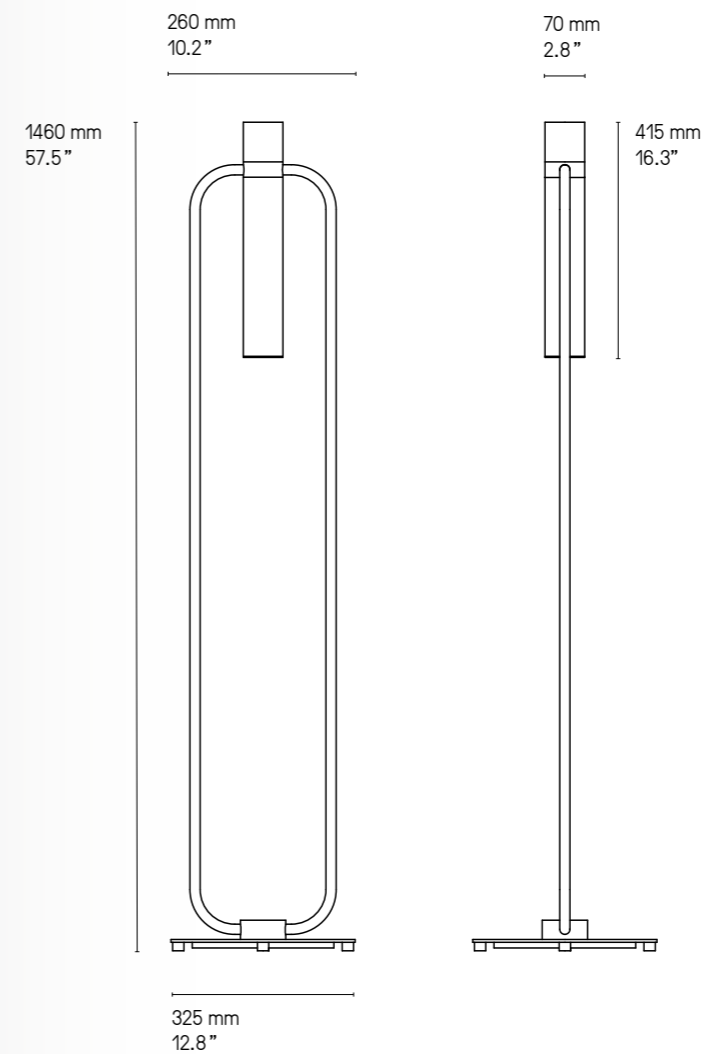

Lampadaire – Floor lamp
Storm SB

Suspension – Pendant

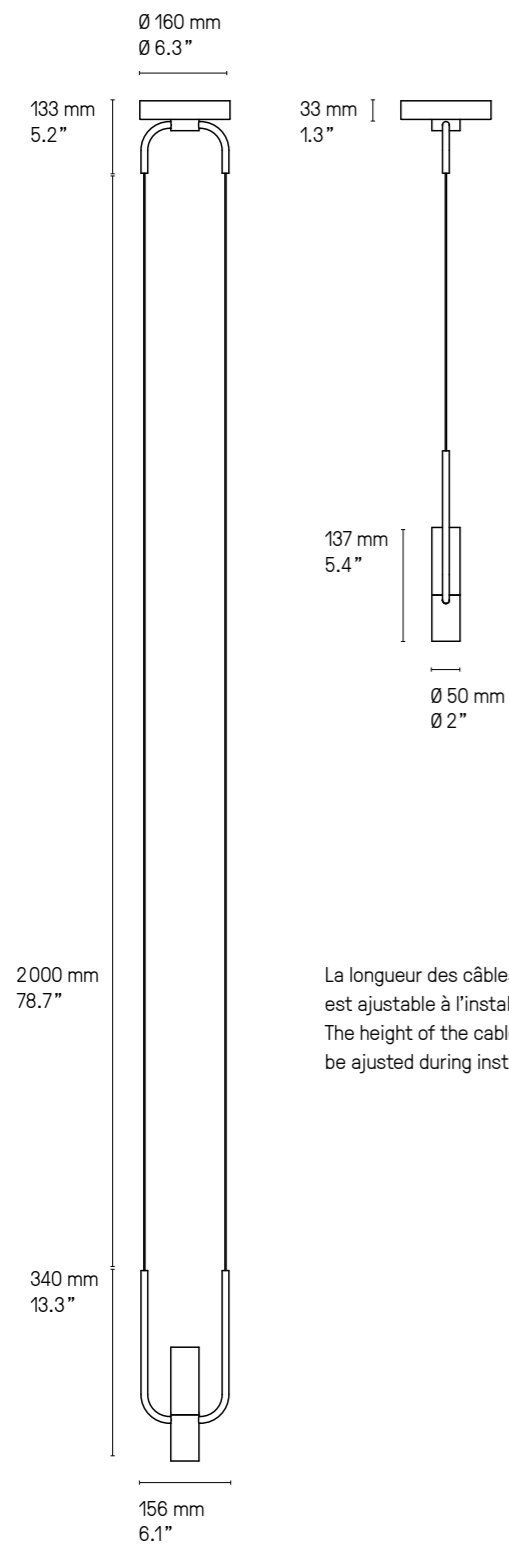

La longueur des câbles est ajustable à l'installation.
The height of the cables can be adjusted during installation.



Suspension – Pendant Storm SB

Suspension – Pendant Storm SG



Suspension – Pendant Storm SB



STRATE

Collection de formes reliées par un trait lumineux, *Strate*, véritable sculpture, orne le mur aussi bien à la verticale qu'à l'horizontale. Par ses dimensions généreuses, elle habille l'espace et en devient une pièce maîtresse.



A collection of shapes linked by a luminous line, *Strate*, an authentic sculpture, adorns the wall both vertically and horizontally. With its generous dimensions, it covers the room and becomes a centerpiece.

Finitions ①+②
Finishes

- Laiton satiné
SB Satin brass
- Graphite satiné
SG Satin graphite
- Nickel satiné
SN Satin nickel
- Cuivre satiné
SC Satin copper

Détails page 239

Matériaux Material	Laiton massif Solid Brass	Diffuseur en polycarbonate Polycarbonate diffuser
-------------------------------------	------------------------------	--

Source Lamping	Strate 150					
	LED intégrée	6100 lm	2700°K	80 W	Alim. électronique 24 V intégrée	Variable (phase cut)
	Integrated LED	6100 lm	2700°K	80 W	Integrated 24 V power supply	Dimmable (phase cut)
	Strate 100					
LED intégrée	3800 lm	2700°K	48 W	Alim. électronique 24 V intégrée	Variable (phase cut)	
Integrated LED	3800 lm	2700°K	48 W	Integrated 24 V power supply	Dimmable (phase cut)	

Designer Émilie Cathelineau



Strate Score 150 SG/SB

US Version
fitted plate to cover outlet power box

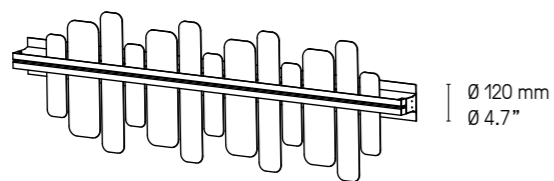

Chaque modèle peut s'installer à la verticale ou à l'horizontale.
Each model can be installed vertically or horizontally.

Strate Score 150

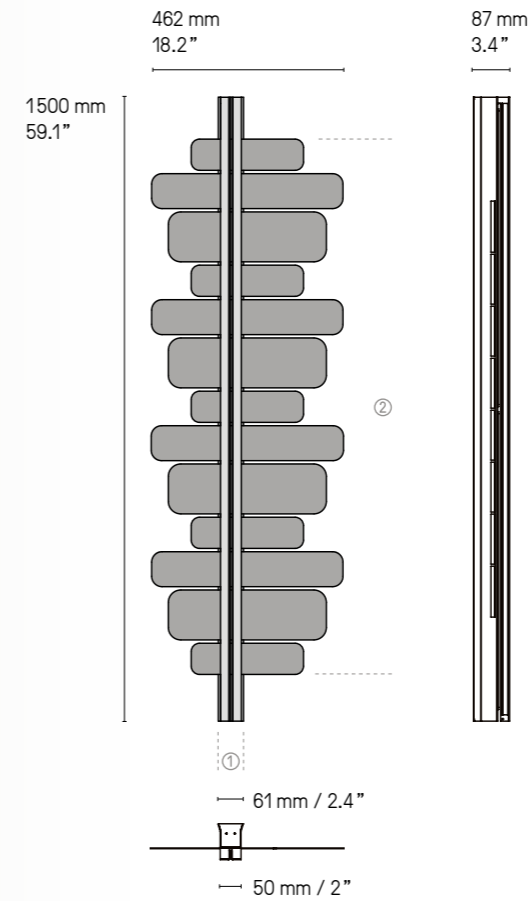

Strate Score 150 SG/SB

Strate Score 100

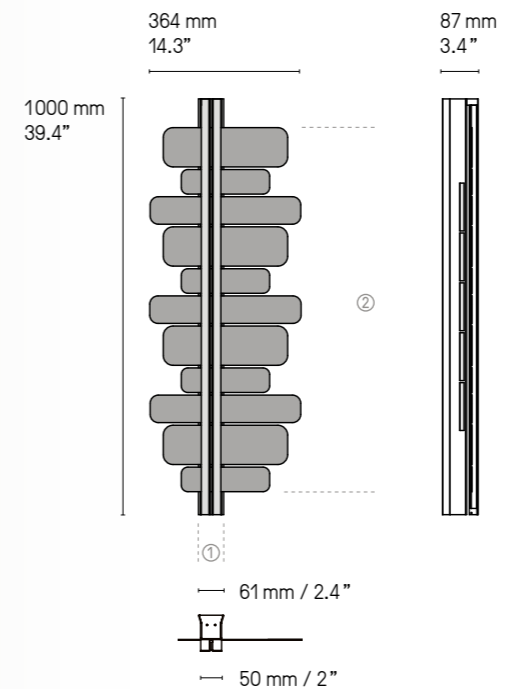

Strate Score 100 SG/SN

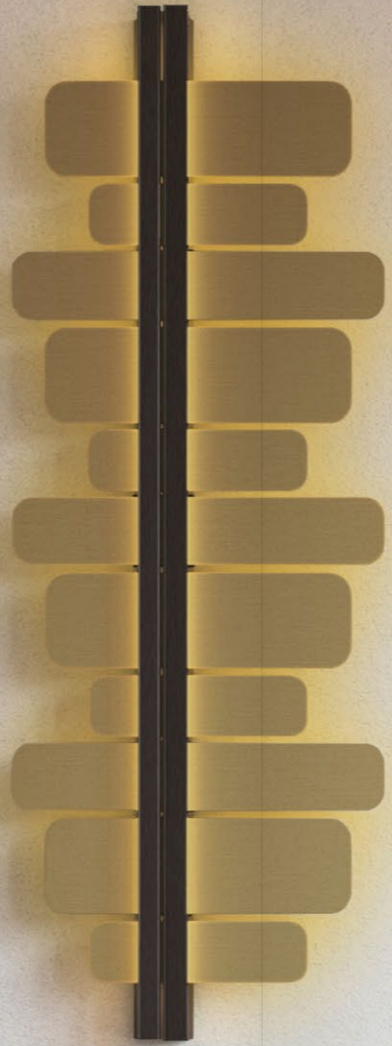

Strate Stone 150

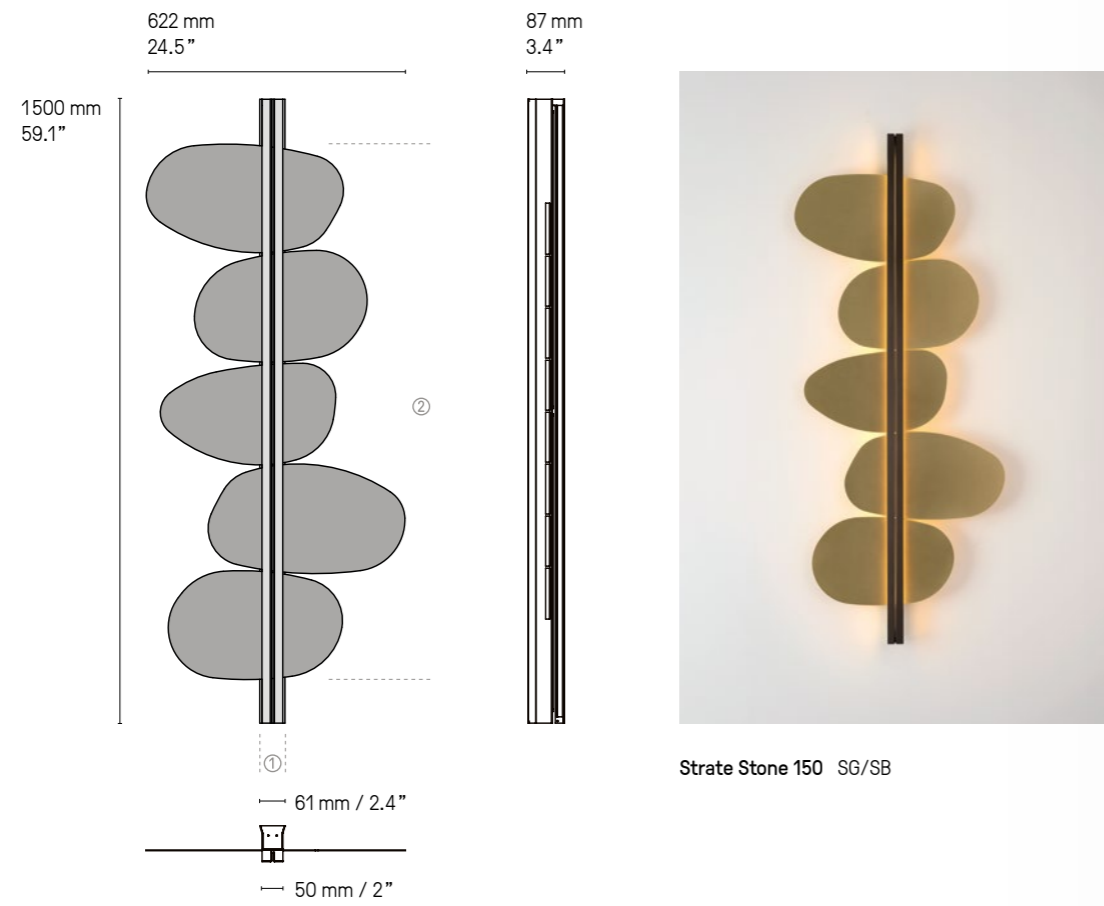

Strate Spi 150

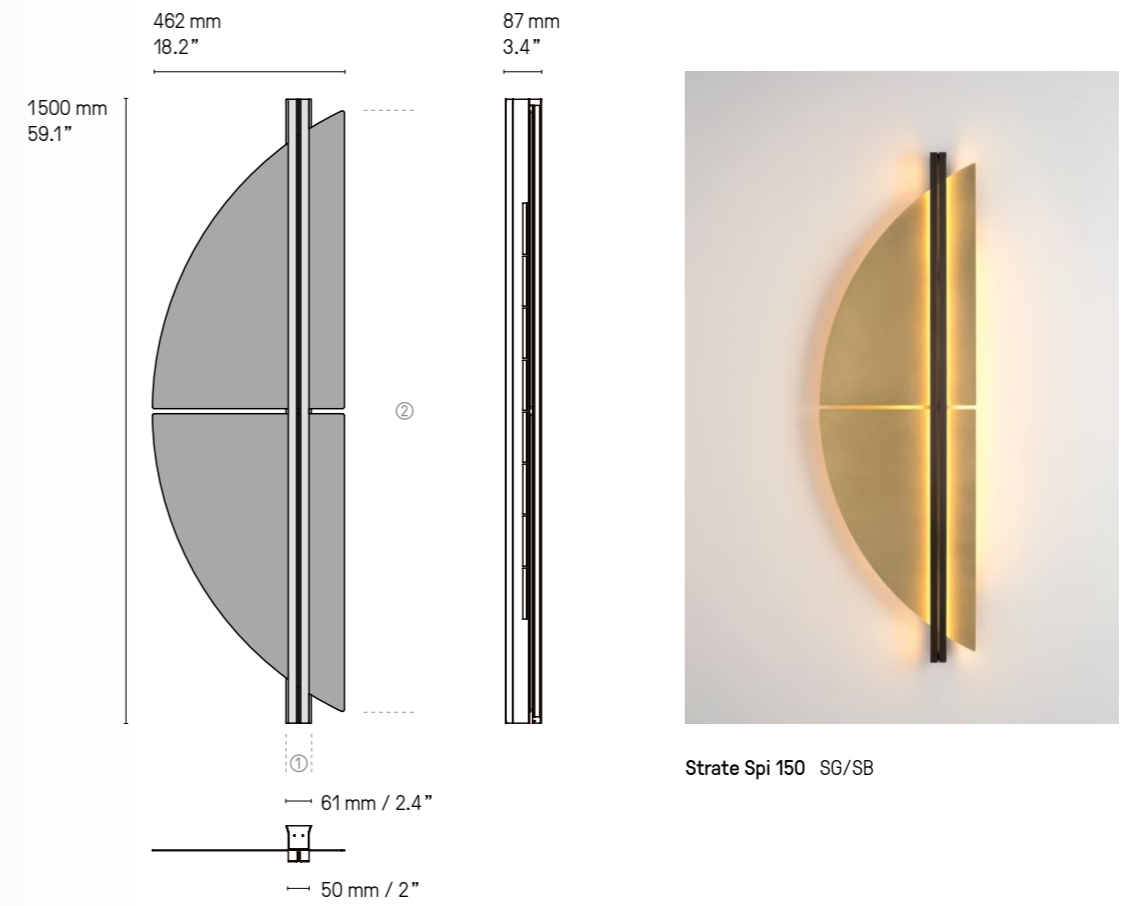

Strate Stone 100

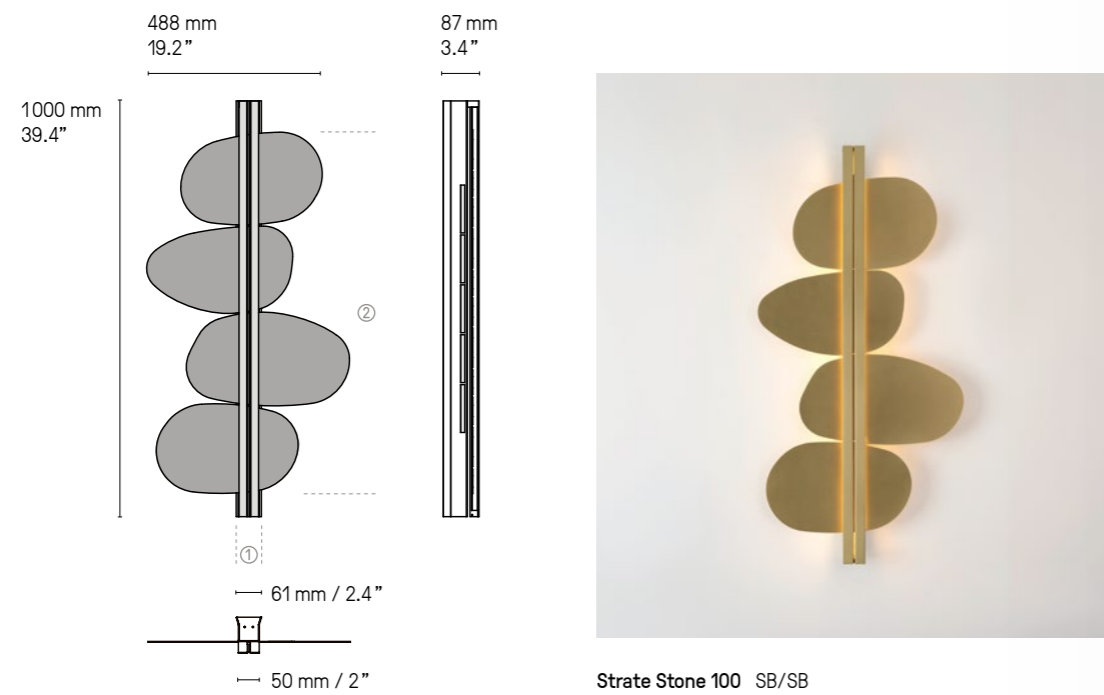

Strate Spi 100

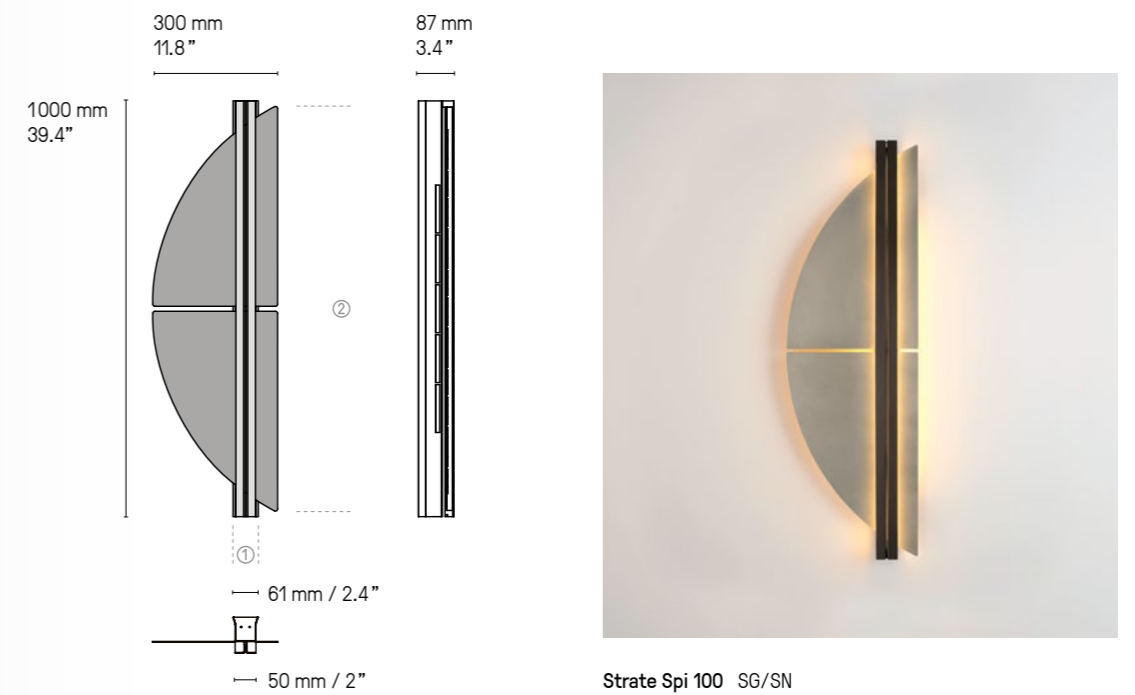



Strate Moon 150

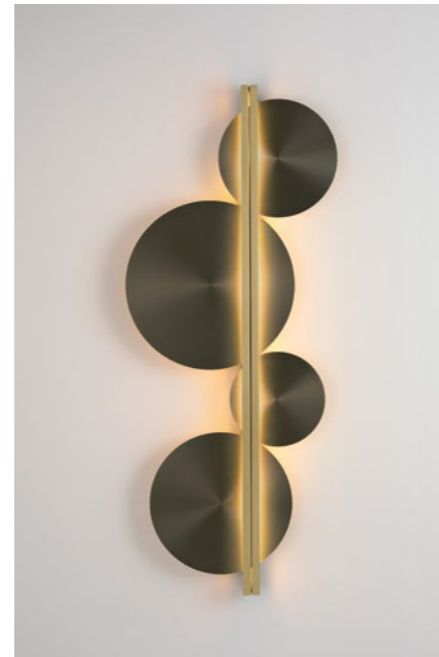
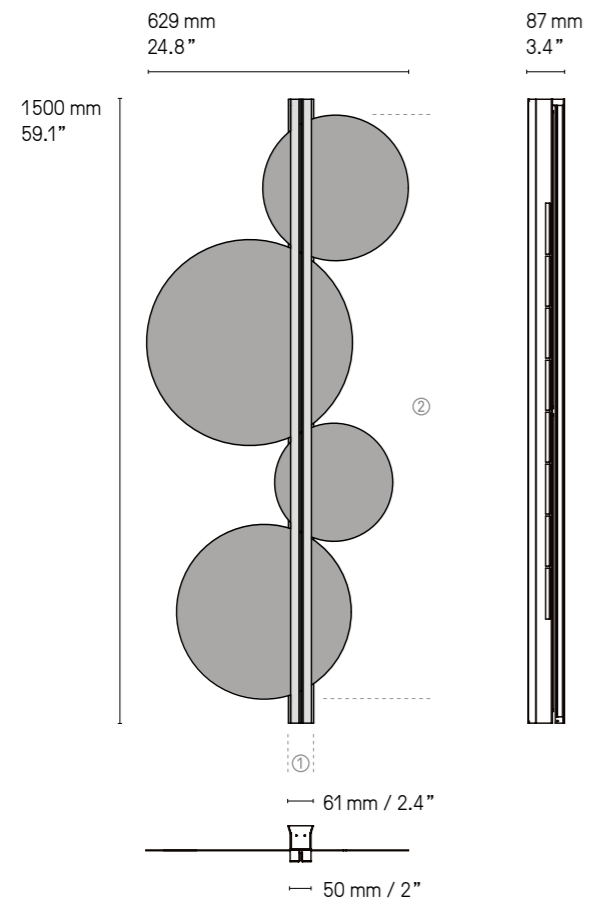

Strate Moon 150 SB/SG

Strate Moon 100

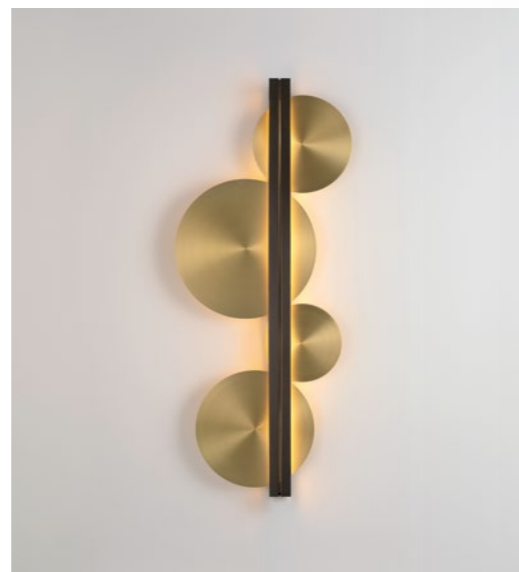
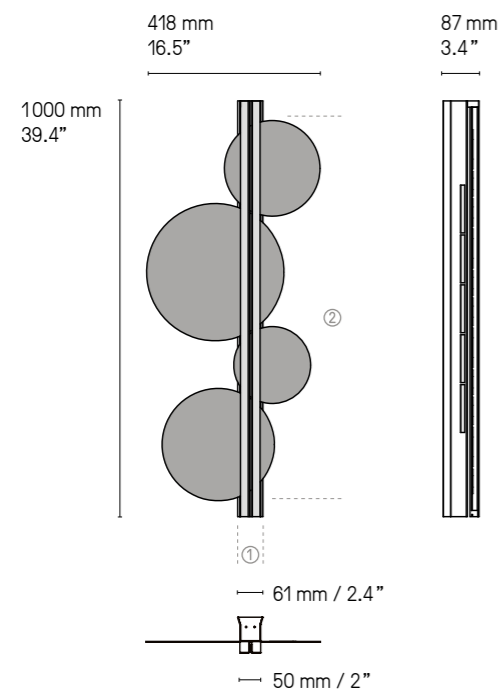

Strate Moon 100 SG/SB



Strate Moon 150 SG/SB



TÉTRA

Seul ou en composition, le module triangulaire *Tétra* dessine par la lumière vos inspirations. Un objet sobre se multipliant à l'infini.



By itself or as an arrangement, the triangular module *Tétra* can shape your own creation with light. A simple object that can be multiplied endlessly.

Finitions
Finishes

Détails page 239

● Laiton satiné SB Satin brass	● Graphite satiné SG Satin graphite	● Nickel satiné SN Satin nickel	● Cuivre satiné SC Satin copper
● Laiton poli PB Polished brass	● Graphite poli PG Polished graphite	● Nickel poli PN Polished nickel	● Cuivre poli PC Polished copper

Matériaux
Material

Laiton massif Solid Brass	Diffuseur en polycarbonate Polycarbonate diffuser
------------------------------	--

Description
Features

Lorsqu'ils sont positionnés côte à côte, les luminaires *Tétra* peuvent être interconnectés grâce à un câble circulant entre le mur et l'arrière du luminaire. Ce montage ne nécessite qu'une seule sortie électrique. Veuillez noter que le système d'interconnexion n'est pas certifié UL.

Positioned side by side, *Tétra* lights can be interconnected with a cable that runs between the wall and the back of the lights. This arrangement requires only one electrical outlet. Please be aware that this interconnected system is not up to code in the US and is not UL certified.

Source
Lamping

LED intégrée	700 lm	2700°K	8W	Alim. électr. intégrée	Variation (phase cut)
Integrated LED	700 lm	2700°K	8W	Integrated power supply	Dimmable (phase cut)
 Integrated LED	700 lm	2700°K	8W	Integrated power supply	Not dimmable

Designer

Émilie Cathelineau

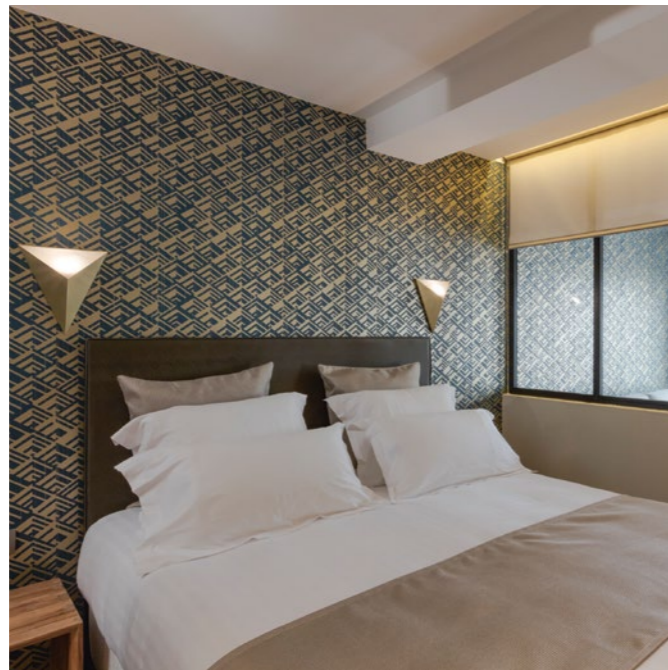

Tétra SB

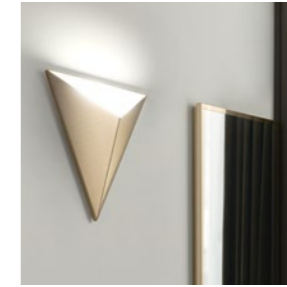
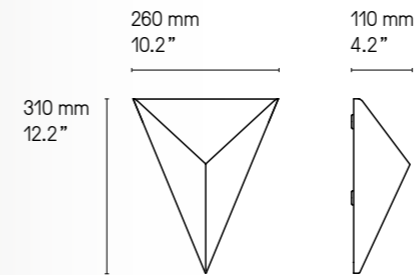

Tétra SB

Exemples de compositions
Examples of arrangements

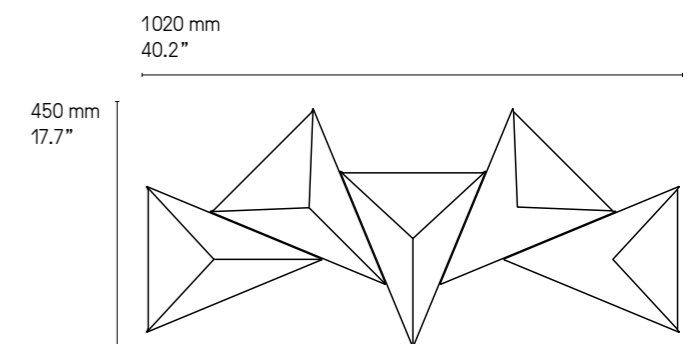
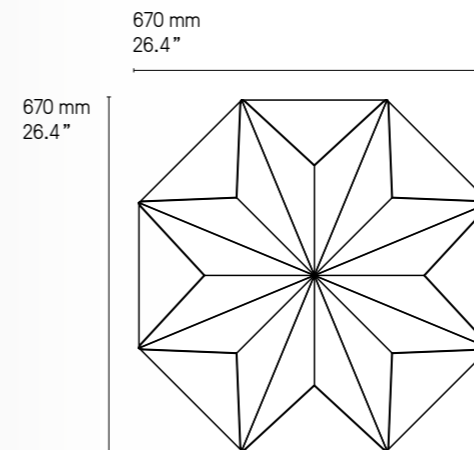
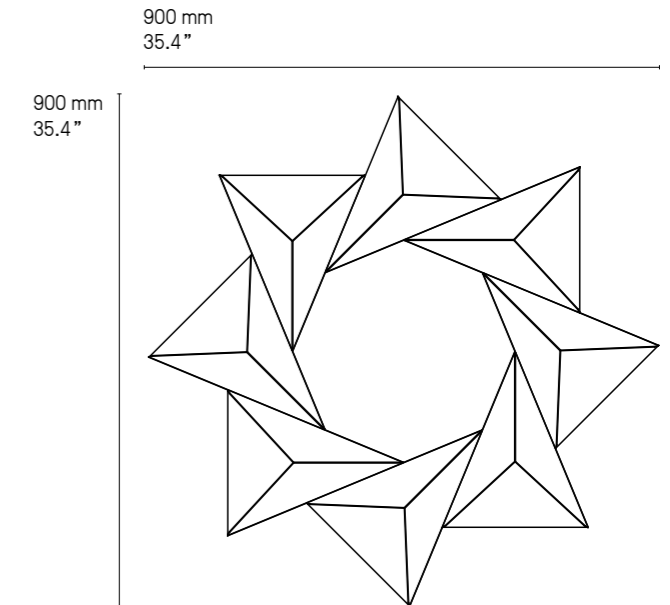
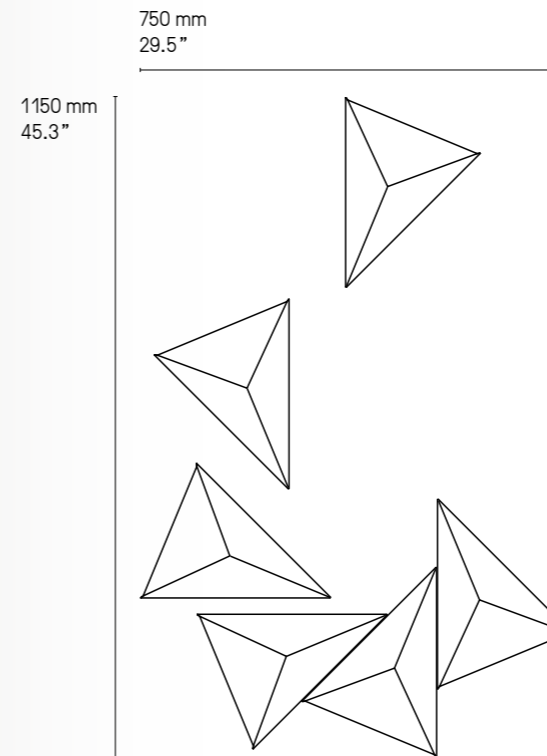



UPPER

Lampadaire unique aux dimensions généreuses, *Upper* investit l'espace comme un objet à la fois utile et précieux. Inspiré des gratte-ciel de Manhattan, ses lignes invitent le regard à monter vers le ciel.



A unique floor lamp with large dimensions, *Upper* uses space as a valuable and useful object. Tall with straight brass tubes, this light is inspired by Manhattan's skyscrapers.

Finitions
Finishes

Détails page 239

● Laiton satiné SB Satin brass	● Graphite satiné SG Satin graphite	● Nickel satiné SN Satin nickel	● Cuivre satiné SC Satin copper
● Laiton poli PB Polished brass	● Graphite poli PG Polished graphite	● Nickel poli PN Polished nickel	● Cuivre poli PC Polished copper

Abat-jour
Lampshade

□ Drop Paper® 100	■ Drop Paper® 101
-------------------	-------------------

Matériaux
Material

Laiton massif Solid Brass	Abat-jour Drop Paper® M1 Lampshade Drop Paper® M1	Câble textile noir (longueur ≈ 2 m) Black textile cable (length ≈ 78.7")
------------------------------	--	---

Source
Lamping

3 x E27 LED 15W max. non fournie 3 x E27 LED 15W max. not included	Variateur à pied Foot operated dimmer	Variation* Dimming*
 3 x E26 type A 60W. Bulb not included	Variateur à pied Foot operated switch	

Designer

Hervé Langlais

* Les luminaires variables nécessitent l'utilisation d'ampoules compatibles avec la variation.
All dimmable light fixtures require the use of compatible bulbs.

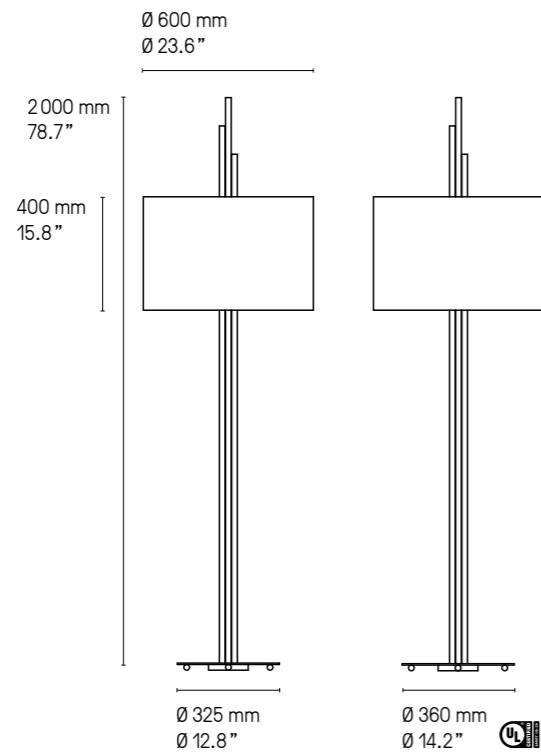

Upper SB

Version LED et DALI sur demande.
LED and DALI version upon request.



WONDER

Inspirée des lampes de poche de notre enfance, *Wonder* se décline en appliques et en lampes dans un format XL. Un brin de nostalgie dans cette collection aux nombreuses variantes grâce à une gamme de couleurs originales, mariées à nos finitions métalliques.



Inspired by our childhood's flashlights, *Wonder* offers a variety of wall lights and XL lamps. An ounce of nostalgia in this wide-ranging collection with several original colors available, combined with metal finishing.

Finitions Finishes ①

Détails page 239

● Laiton satiné SB Satin brass	● Graphite satiné SG Satin graphite	● Nickel satiné SN Satin nickel	● Cuivre satiné SC Satin copper
● Laiton poli PB Polished brass	● Graphite poli PG Polished graphite	● Nickel poli PN Polished nickel	● Cuivre poli PC Polished copper

Finitions Finishes ②

Détails page 239

● Bleu foncé DB Dark Blue	● Bleu clair LB Light Blue	● Goyave GU Guava	● Bordeaux DR Dark Red
● Mangue MA Mango	● Vert vintage VG Vintage Green		
● Laiton satiné SB Satin brass	● Graphite satiné SG Satin graphite	● Nickel satiné SN Satin nickel	● Cuivre satiné SC Satin copper

Matériaux Material

Tous – All Laiton massif et acier peint Solid Brass and painted steel	Diffuseur PMMA texturé Textured PMMA diffuser	Lampe de Table – Table Lamp Câble textile noir Black textile cable
--	--	---

Source Lamping

Appliques – Wall lights					
Applique – Wall light XS					
LED intégrée	430 lm	2700°K	4W	230V direct	Variable (phase cut)
Integrated LED	430 lm	2700°K	4W	230V direct	Dimmable (phase cut)
Applique – Wall light XL					
LED intégrée	430 lm	2700°K	4W	230V direct	Variable (phase cut)
Integrated LED	430 lm	2700°K	4W	230V direct	Dimmable (phase cut)
Lampe de table – Table lamp					
Lampe de table – Table lamp					
LED intégrée	1060 lm	2700°K	9W	Alim. intégrée 110-220V	Variable
Integrated LED	1060 lm	2700°K	9W	Power supply 110-220V	Dimmable

Designer

Émilie Cathelineau



Bouton de variation au dos de la lampe.
Dimming button at the back of the lamp.

Lampe de table – Table lamp

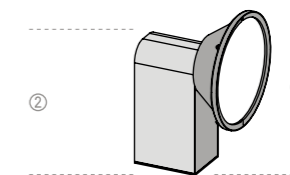
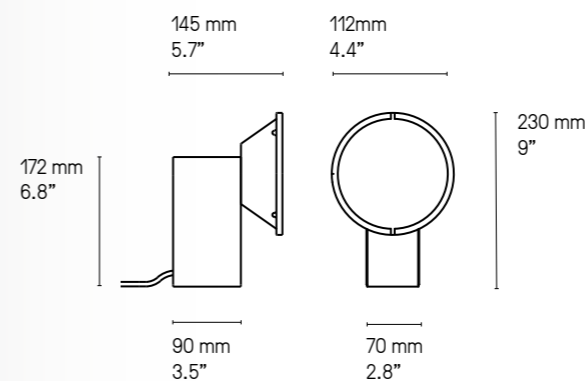

Lampes de table – Table lamps

A Wonder PB/SG	E Wonder SG/SB
B Wonder PG/MA	F Wonder SN/LB
C Wonder PN/DR	G Wonder SG/VG
D Wonder SB/GU	H Wonder SB/DB

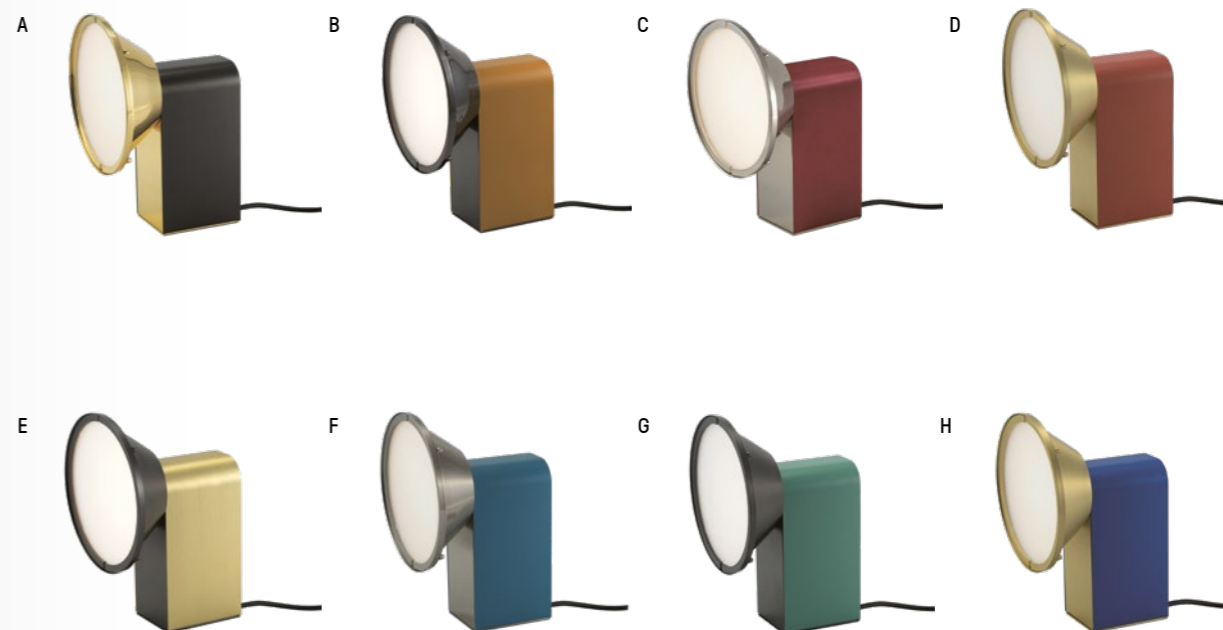

Applique XS V1 – Wall light XS V1

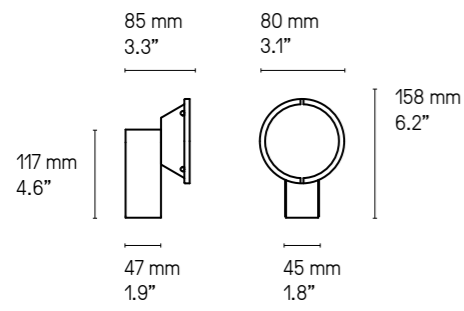

Applique XL V1 – Wall light XL V1

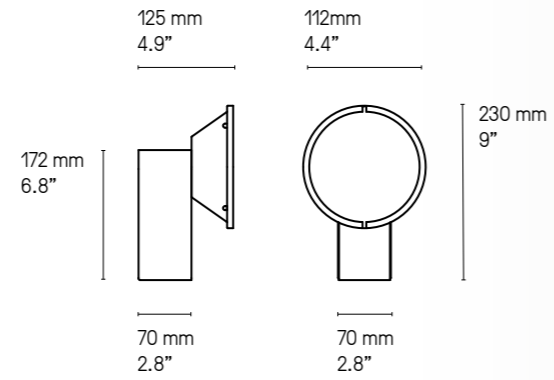

XL V1 SB/SG



XL V1 SN/LB



XL V1 SG/SB



XS V1 SB/DB

Les appliques *Wonder* ne sont pas réglables. V1 et V2 sont des modèles différents.
Wonder wall lights are not mobile. V1 and V2 are different fixed models.

Applique XS V2 – Wall light XS V2

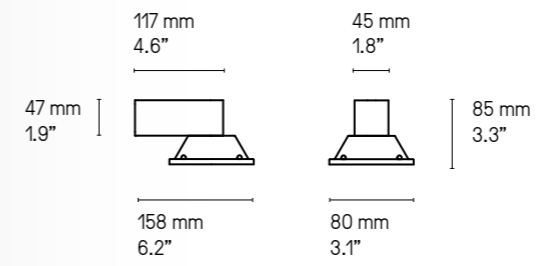

XL V2 SB/DR



XL V2 SB/GU



XL V2 SB/VG



Applique XL V2 – Wall light XL V2

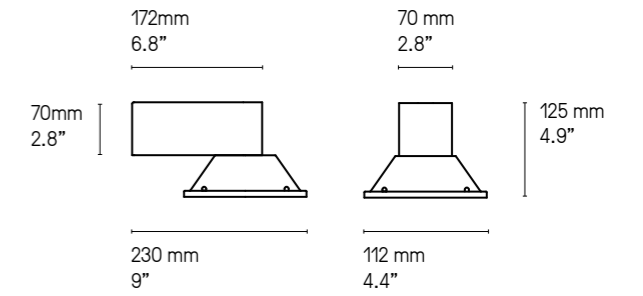

XL V2 SB/VG

Les appliques *Wonder* ne sont pas réglables. V1 et V2 sont des modèles différents.
Wonder wall lights are not mobile. V1 and V2 are different fixed models.



CVL

APPLIQUES SALLE DE BAIN BATHROOM WALL LIGHTS

Élégance des formes, aux accents minimalistes et aux finitions soignées. Retrouvez l'esprit CVL dans une collection d'appliques esthétiques et fonctionnelles, spécifiquement conçues pour la salle de bain.



Elegant shapes, minimalist accents and immaculate finishes. Find the CVL spirit in a collection of aesthetic and functional wall lights, specifically designed for bathrooms.



IP BACKSTAGE



Finitions Finishes

Détails page 239

● Laiton satiné SB Satin brass	● Graphite satiné SG Satin graphite	● Nickel satiné SN Satin nickel	● Cuivre satiné SC Satin copper
● Laiton poli PB Polished brass	● Graphite poli PG Polished graphite	● Nickel poli PN Polished nickel	● Cuivre poli PC Polished copper

Matériaux Material

Laiton massif Solid Brass	Verre triplex opale soufflé bouche Opal triplex mouth-blown glass
------------------------------	--

Source Lamping

IP Backstage 4					
LED intégrée	520 lm	3 000°K	5W	Alimentation 24V intégrée	Non variable en standard
Integrated LED	520 lm	3 000°K	5W	Int. power supply 24V incl.	Standard version not dim.
IP Backstage 6					
LED intégrée	780 lm	3 000°K	7W	Alimentation 24V intégrée	Non variable en standard
Integrated LED	780 lm	3 000°K	7W	Int. power supply 24V incl.	Standard version not dim.
IP Backstage 8					
LED intégrée	1040 lm	3 000°K	9W	Alimentation 24V intégrée	Non variable en standard
Integrated LED	1040 lm	3 000°K	9W	Int. power supply 24V incl.	Standard version not dim.
IP Backstage Corner 4					
LED intégrée	520 lm	3 000°K	5W	Alimentation 24V intégrée	Non variable en standard
Integrated LED	520 lm	3 000°K	5W	Int. power supply 24V incl.	Standard version not dim.
IP Backstage Corner 6					
LED intégrée	780 lm	3 000°K	7W	Alimentation 24V intégrée	Non variable en standard
Integrated LED	780 lm	3 000°K	7W	Int. power supply 24V incl.	Standard version not dim.
IP Backstage Corner 8					
LED intégrée	1040 lm	3 000°K	9W	Alimentation 24V intégrée	Non variable en standard
Integrated LED	1040 lm	3 000°K	9W	Int. power supply 24V incl.	Standard version not dim.

Norme Standard

IP44	Classe II
IP44	Class II

Designer

Émilie Cathelineau

IP Backstage Linear L8

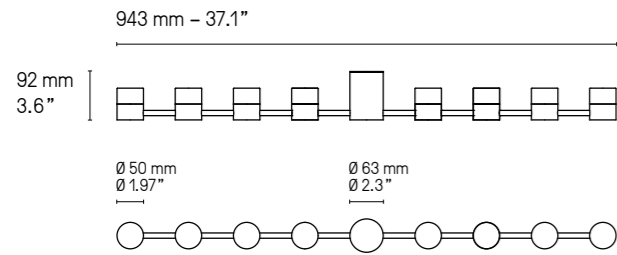

IP Backstage Corner C8

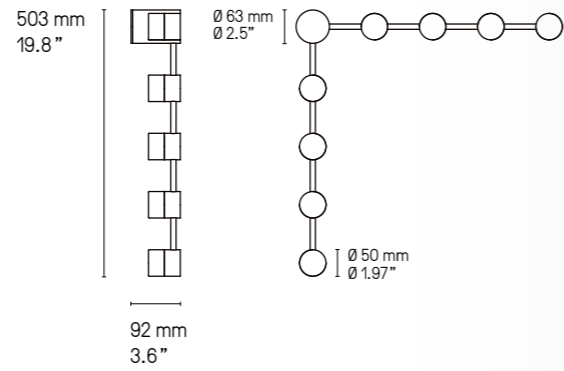

IP Backstage Linear L6

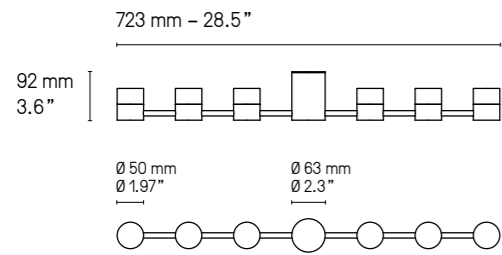

IP Backstage Corner C6

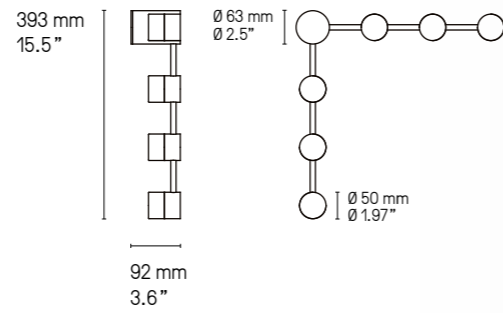

IP Backstage Linear L4

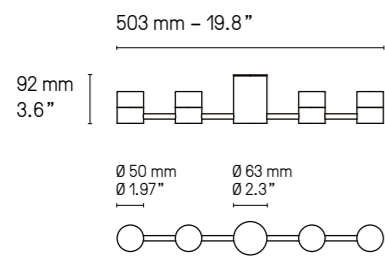

IP Backstage Corner C4

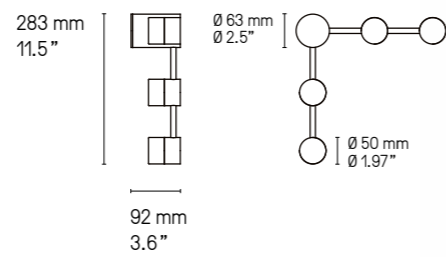

**US Version
fitted plate to cover outlet power box**

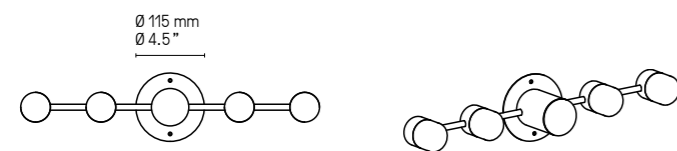



IP Backstage Corner C8 SG



IP Backstage Linear L6 PN



IP Backstage Linear L4 SB



IP Backstage Linear L6 SG



IP Backstage Corner C8 PB



IP CALÉ(E)



Finitions Finishes ① + ②

Détails page 239

● Laiton satiné SB Satin brass	● Graphite satiné SG Satin graphite	● Nickel satiné SN Satin nickel	● Cuivre satiné SC Satin copper
● Laiton poli PB Polished brass	● Graphite poli PG Polished graphite	● Nickel poli PN Polished nickel	● Cuivre poli PC Polished copper

Matériaux Material

Laiton massif Solid Brass	Diffuseur polycarbonate satiné Satin Polycarbonate diff user
------------------------------	---

Source Lamping

LED intégrée Integrated LED	880 lm	3 000°K	10W	Alimentation 24 V intégrée Int. power supply 24 V incl.	Variable (phase cut) Dimmable (phase cut)
--------------------------------	--------	---------	-----	--	--

Norme Standard

IP44	Classe II
IP44	Class II

Designer

POOL

VH

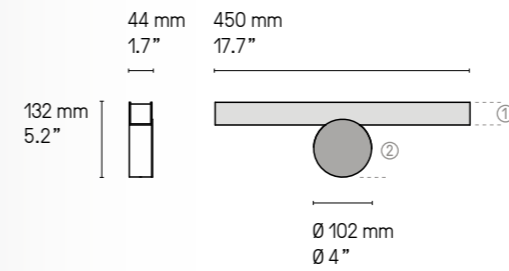

VV

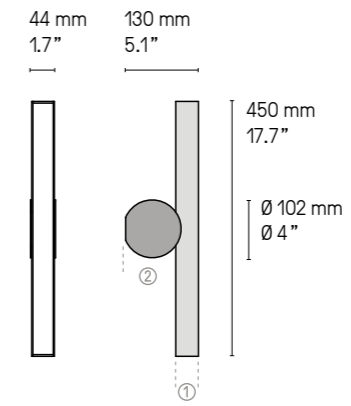

VF

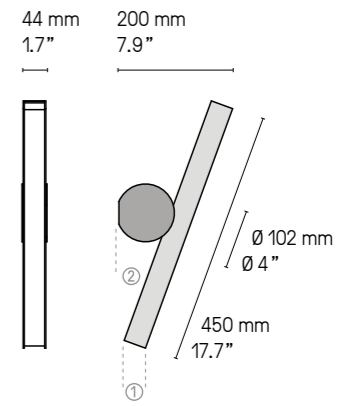

Les appliques Calé(e)s ne sont pas réglables. Ce sont 3 modèles différents.
Calé(e) wall lights are not mobile. These are 3 different fixed models.



IP CORNET



Finitions Finishes	● Laiton satiné SB Satin brass	● Graphite satiné SG Satin graphite	● Nickel satiné SN Satin nickel	● Cuivre satiné SC Satin copper
	● Laiton poli PB Polished brass	● Graphite poli PG Polished graphite	● Nickel poli PN Polished nickel	● Cuivre poli PC Polished copper
Détails page 239				
Matériaux Material	Laiton massif Solid Brass	Verre triplex opale soufflé bouche Opal triplex mouth-blown glass		
Source Lamping	G9 LED 5W max. non fournie G9 LED 5W max. not included	Variable* Dimmable*		
Norme Standard	IP24 IP24	Classe II Class II		
Designer	POOL			

* Les luminaires variables nécessitent l'utilisation d'ampoules compatibles avec la variation.
All dimmable light fixtures require the use of compatible bulbs.

IP Cornet Appliques – Wall mounted lights

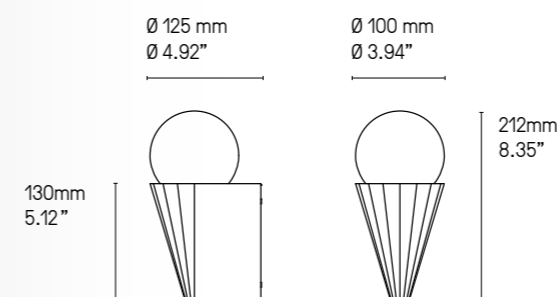

IP Cornet PN



IP GAMMA



Finitions Finishes

Détails page 239

● Laiton satiné SB Satin brass	● Graphite satiné SG Satin graphite	● Nickel satiné SN Satin nickel	● Cuivre satiné SC Satin copper
● Laiton poli PB Polished brass	● Graphite poli PG Polished graphite	● Nickel poli PN Polished nickel	● Cuivre poli PC Polished copper

Matériaux Material

Laiton massif Solid Brass	Diffuseur polycarbonate blanc White Polycarbonate diffuser
------------------------------	---

Source Lamping

LED intégrée Integrated LED	500 lm 500 lm	3000°K 8W 3000°K 8W	Alimentation 24V intégrée Int. power supply 24V incl.	Non variable en standard Standard version not dim.
--------------------------------	------------------	------------------------	--	---

Norme Standard

IP44	Classe II
IP44	Class II

Designer

Sylvain Willenz

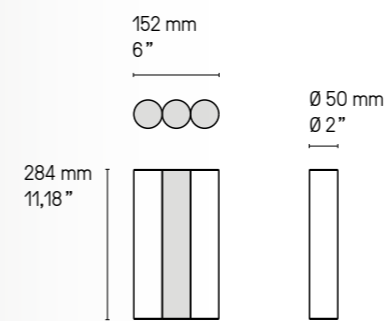

IP Gamma SB

IP Gamma SG

IP Gamma SN

IP Gamma SC



IP JANED



Finitions Finishes ①+②

Détails page 239

● Laiton satiné SB Satin brass	● Graphite satiné SG Satin graphite	● Nickel satiné SN Satin nickel	● Cuivre satiné SC Satin copper
● Laiton poli PB Polished brass	● Graphite poli PG Polished graphite	● Nickel poli PN Polished nickel	● Cuivre poli PC Polished copper

Matériaux Material

Laiton massif Solid Brass	Verre triplex opale Opal triplex glass
------------------------------	---

Source Lamping

G9 LED 5W max. non fournie G9 LED 5W max. not included	Variable* Dimmable*
---	------------------------

Norme Standard

IP44	Classe II
IP44	Class II

Designer

Émilie Cathelineau

* Les luminaires variables nécessitent l'utilisation d'ampoules compatibles avec la variation.
All dimmable light fixtures require the use of compatible bulbs.

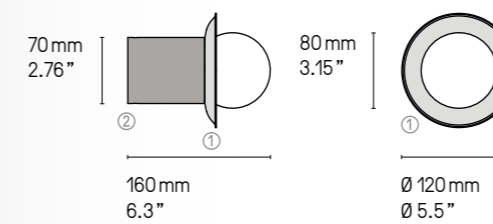

IP Janed 160 SG



IP Janed 160 SN



IP LINK



Finitions Finishes

Détails page 239

● Laiton satiné SB Satin brass	● Graphite satiné SG Satin graphite	● Nickel satiné SN Satin nickel	● Cuivre satiné SC Satin copper
● Laiton poli PB Polished brass	● Graphite poli PG Polished graphite	● Nickel poli PN Polished nickel	● Cuivre poli PC Polished copper

Matériaux Material

Laiton massif Solid Brass	Diffuseur polycarbonate satiné Satin Polycarbonate diff user	Ruban Led sans points visibles Led strip without visible dots
------------------------------	---	--

Source Lamping

IP Link 410 (410 mm - 16.1")			
LED intégrée 160 lm	3 000°K 2W	Alimentation 24V intégrée	Non variable en standard
Integrated LED 160 lm	3 000°K 2W	Int. power supply 24 V incl.	Standard version not dim.
IP Link 580 (580 mm - 22.8")			
LED intégrée 330 lm	3 000°K 4W	Alimentation 24V intégrée	Non variable en standard
Integrated LED 330 lm	3 000°K 4W	Int. power supply 24 V incl.	Standard version not dim.
IP Link double 610 (610 mm - 24.1")			
LED intégrée 320 lm	3 000°K 4W	Alimentation 24V intégrée	Non variable en standard
Integrated LED 320 lm	3 000°K 4W	Int. power supply 24 V incl.	Standard version not dim.
IP Link double 960 (960 mm - 37.8")			
LED intégrée 660 lm	3 000°K 7W	Alimentation 24V intégrée	Non variable en standard
Integrated LED 660 lm	3 000°K 7W	Int. power supply 24 V incl.	Standard version not dim.
IP Link double 1300 (1300 mm - 51.2")			
LED intégrée 880 lm	3 000°K 10W	Alimentation 24V intégrée	Non variable en standard
Integrated LED 880 lm	3 000°K 10W	Int. power supply 24 V incl.	Standard version not dim.

Norme Standard

IP44	Classe II
IP44	Class II

Designer

Émilie Cathelineau

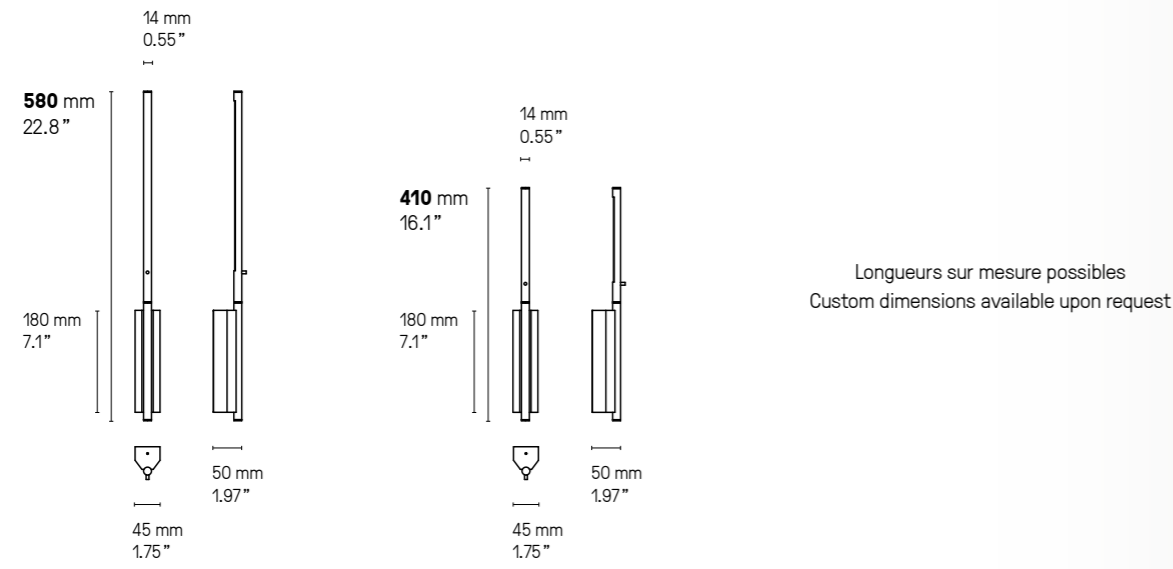

Longueurs sur mesure possibles
Custom dimensions available upon request

Double
1300 mm / 51.2"

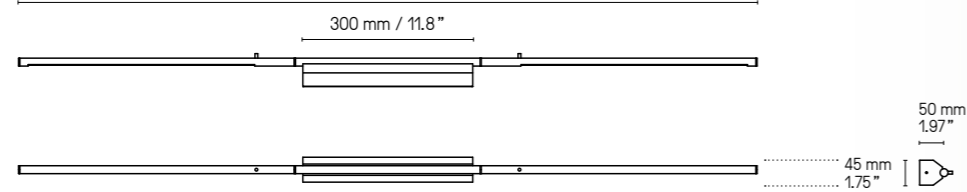

Double
960 mm / 37.8"

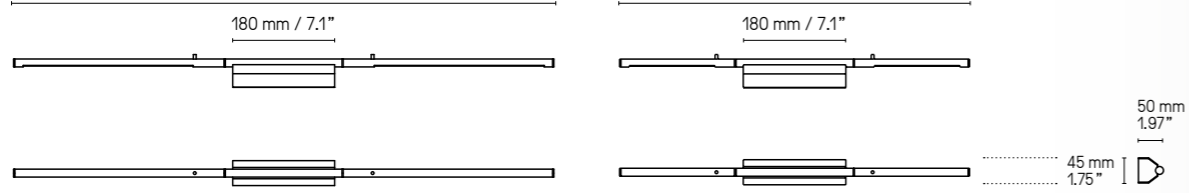

Double
610 mm / 24.1"

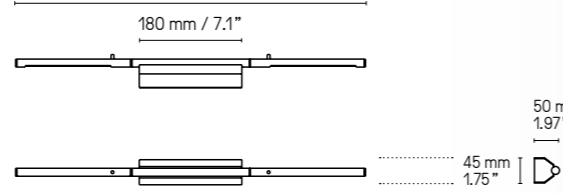

IP Link Double 960 PG



IP Link 410 SB



IP METROP



Finitions Finishes ① + ②

Détails page 239

● Laiton satiné SB Satin brass	● Graphite satiné SG Satin graphite	● Nickel satiné SN Satin nickel	● Cuivre satiné SC Satin copper
● Laiton poli PB Polished brass	● Graphite poli PG Polished graphite	● Nickel poli PN Polished nickel	● Cuivre poli PC Polished copper

Matériaux Material

Laiton massif Solid Brass	Diffuseur polycarbonate satiné Satin Polycarbonate diffuser	Ruban Led sans points visibles Led strip without visible dots
------------------------------	--	--

Source Lamping

IP Metrop 325				
LED intégrée	330 lm	3 000°K	4 W	Alimentation 24 V intégrée
Integrated LED	330 lm	3 000°K	4 W	Int. power supply 24 V incl.
IP Metrop 525				
LED intégrée	550 lm	3 000°K	7 W	Alimentation 24 V intégrée
Integrated LED	550 lm	3 000°K	7 W	Int. power supply 24 V incl.
IP Metrop 780				
LED intégrée	825 lm	3 000°K	9 W	Alimentation 24 V intégrée
Integrated LED	825 lm	3 000°K	9 W	Int. power supply 24 V incl.

Norme Standard

IP44	Classe II
IP44	Class II

Designer

Émilie Cathelineau

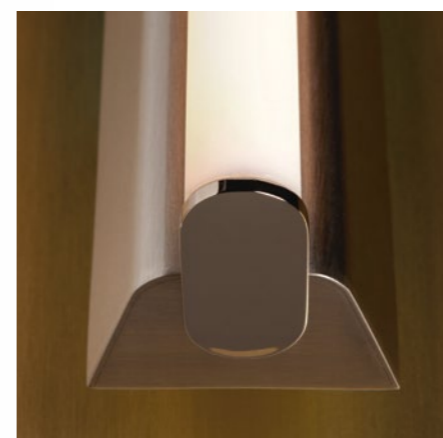

IP Metrop SG/PG



IP Metrop SB/SG

IP Metrop

325 mm
12.8"

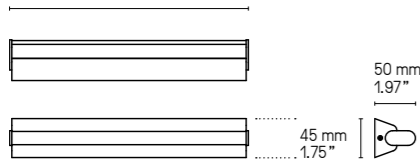

525 mm
20.7"

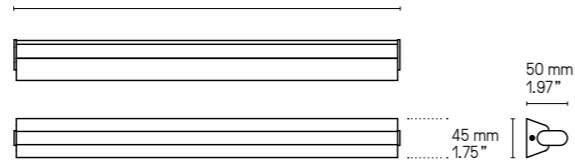

780 mm
30.7"

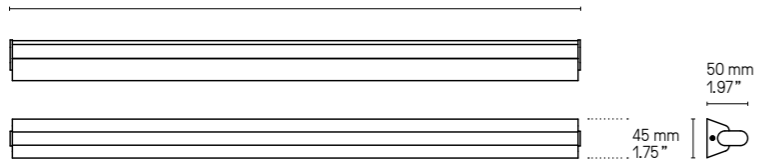

Longueurs sur mesure possibles
Custom dimensions available upon request



IP Metrop 325 PB



IP Metrop 325 SG

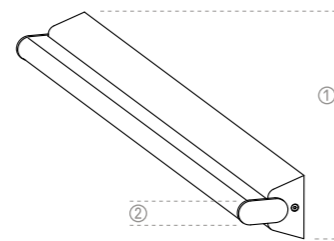

IP Metrop 325 SN/SG



IP Metrop 325 PN

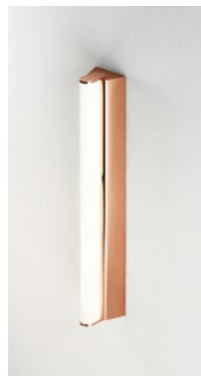

IP Metrop 325 PC

US Version
fitted plate to cover outlet power box

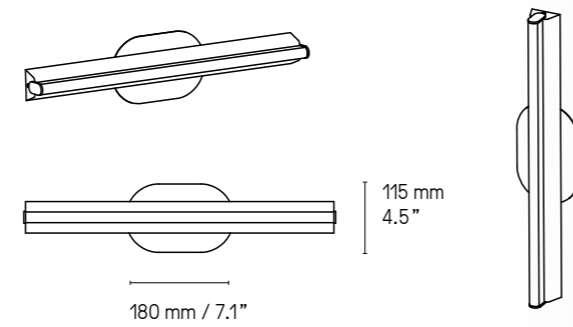

IP Metrop SB/SG



IP SIGNAL



Finitions Finishes

Détails page 239

● Laiton satiné SB Satin brass	● Graphite satiné SG Satin graphite	● Nickel satiné SN Satin nickel	● Cuivre satiné SC Satin copper
● Laiton poli PB Polished brass	● Graphite poli PG Polished graphite	● Nickel poli PN Polished nickel	● Cuivre poli PC Polished copper

Matériaux Material

Laiton massif Solid Brass	Diffuseur polycarbonate satiné Satin Polycarbonate diffuser
------------------------------	--

Source Lamping

IP Signal 375 (375 mm - 14.8")			
LED intégrée	280 lm	3000°K	5W
Integrated LED	280 lm	3000°K	5W
		Alimentation 24 V intégrée Int. power supply 24 V included	Variable (phase cut) Dimmable (phase cut)
IP Signal 475 (475 mm - 18.7")			
LED intégrée	480 lm	3000°K	7W
Integrated LED	480 lm	3000°K	7W
		Alimentation 24 V intégrée Int. power supply 24 V included	Variable (phase cut) Dimmable (phase cut)
IP Signal 575 (575 mm - 22.6")			
LED intégrée	670 lm	3000°K	9W
Integrated LED	670 lm	3000°K	9W
		Alimentation 24 V intégrée Int. power supply 24 V included	Variable (phase cut) Dimmable (phase cut)
IP Signal double 580 (580 mm - 22.8")			
LED intégrée	570 lm	3000°K	7W
Integrated LED	570 lm	3000°K	7W
		Alimentation 24 V intégrée Int. power supply 24 V included	Variable (phase cut) Dimmable (phase cut)
IP Signal double 780 (780 mm - 30.7")			
LED intégrée	960 lm	3000°K	13W
Integrated LED	960 lm	3000°K	13W
		Alimentation 24 V intégrée Int. power supply 24 V included	Variable (phase cut) Dimmable (phase cut)
IP Signal double 980 (980 mm - 38.6")			
LED intégrée	1340 lm	3000°K	17W
Integrated LED	1340 lm	3000°K	17W
		Alimentation 24 V intégrée Int. power supply 24 V included	Variable (phase cut) Dimmable (phase cut)

Norme Standard

IP44	Classe II
IP44	Class II

Designer

Pauline Deltour

IP Signal double 980

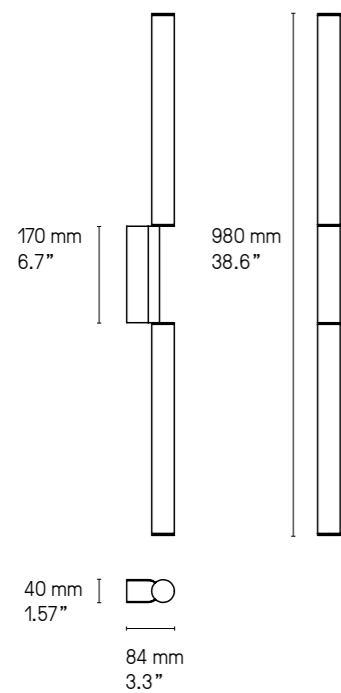

IP Signal double 780

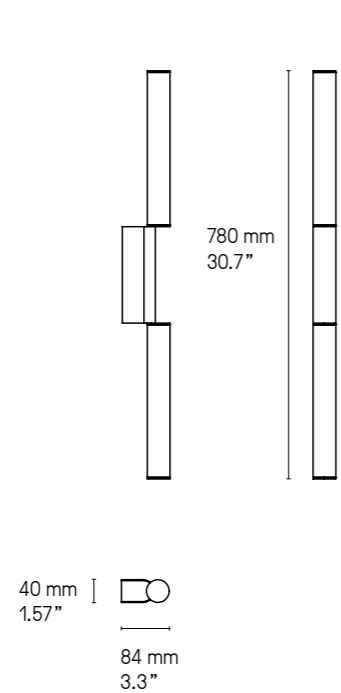

IP Signal double 580

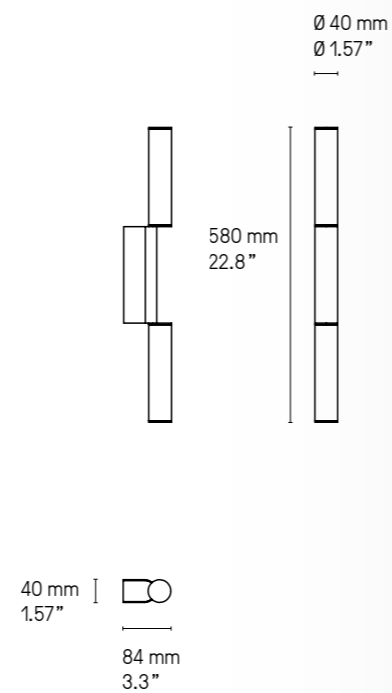

IP Signal simple 575

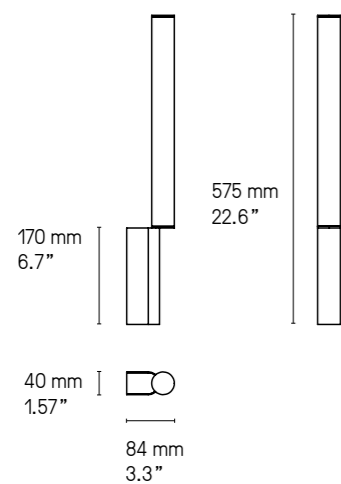

IP Signal simple 475

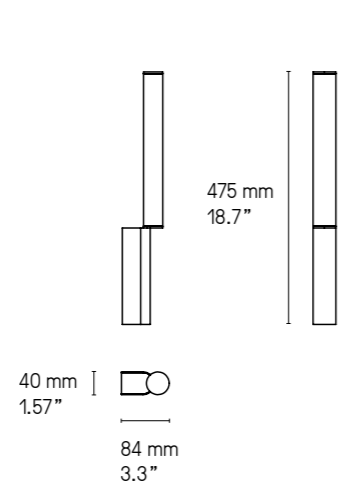

IP Signal simple 375

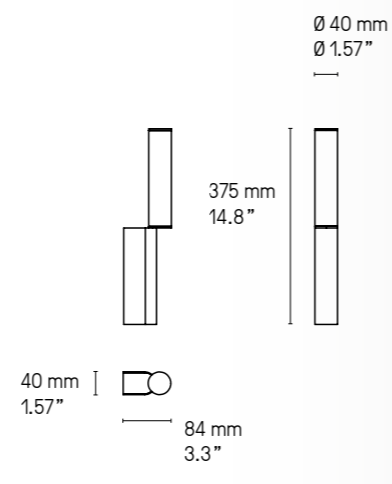

*Signal peut être installée horizontalement ou verticalement.
Signal can be placed both horizontally or vertically on the wall.*



IP Signal Double 980 SN



IP Signal Simple 475 PN



IP Signal Simple 475 PB



IP STORM



Finitions Finishes

Détails page 239

● Laiton satiné SB Satin brass	● Graphite satiné SG Satin graphite	● Nickel satiné SN Satin nickel	● Cuivre satiné SC Satin copper
● Laiton poli PB Polished brass	● Graphite poli PG Polished graphite	● Nickel poli PN Polished nickel	● Cuivre poli PC Polished copper

Matériaux Material

Laiton massif Solid Brass	Diffuseur polycarbonate blanc White Polycarbonate diffuser
------------------------------	---

Source Lamping

LED intégrée Integrated LED	440 lm 440 lm	3 000°K 3 000°K	5W 5W	Alimentation 24V intégrée Int. power supply 24V incl.	Non variable en standard Standard version not dim.
--------------------------------	------------------	--------------------	----------	--	---

Norme Standard

IP44	Classe II
IP44	Class II

Designer

Émilie Cathelineau

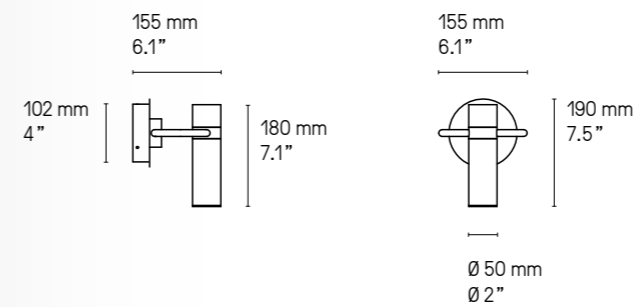

IP Storm SB

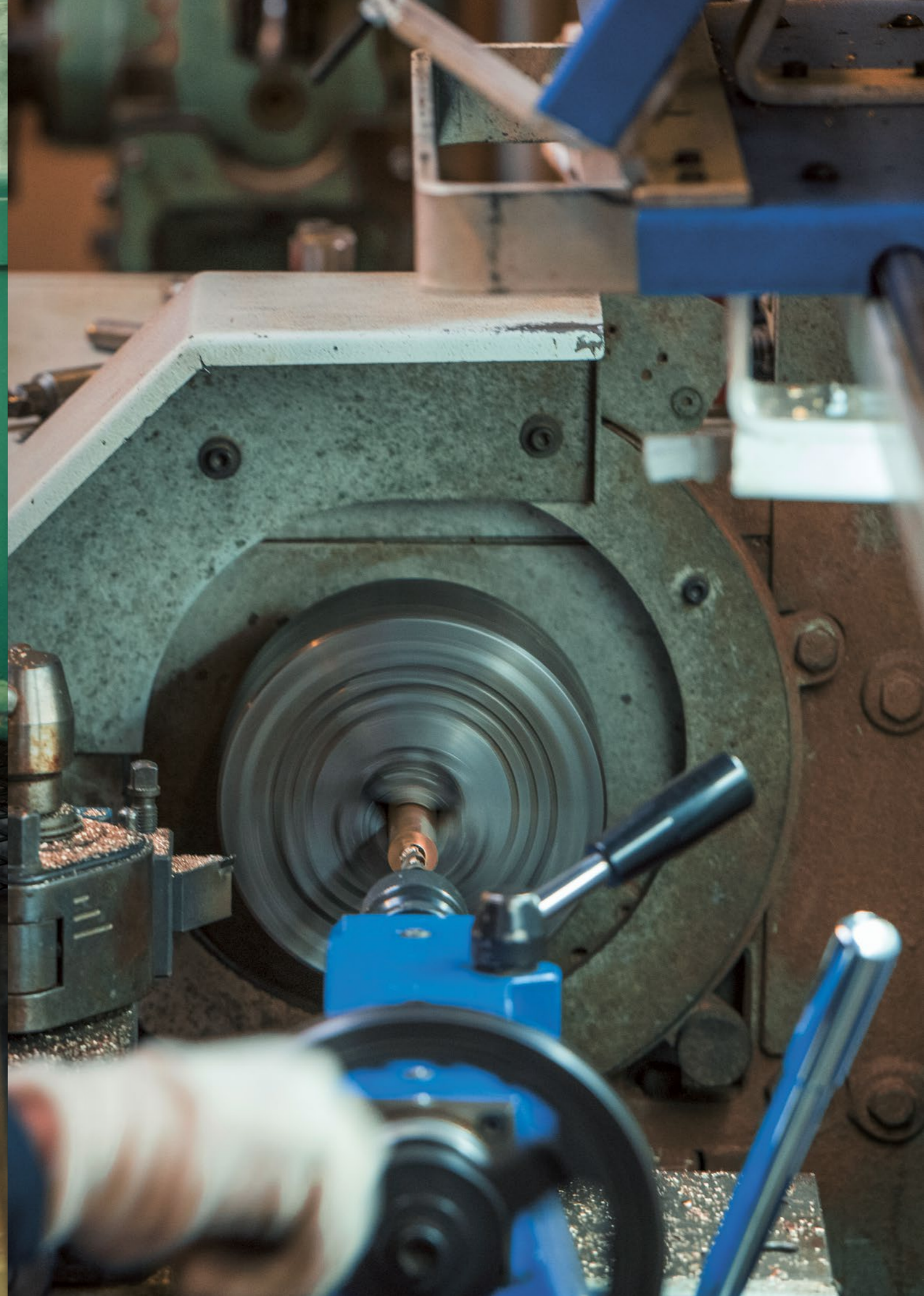





NUANCIER - FINISH OPTIONS



LAITON - BRASS

- | | | | | |
|------------------------------------|---|-------------------------------------|-------------------------------------|--|
| ① Laiton satiné
SB Satin brass | ② Graphite satiné
SG Satin graphite | ③ Nickel satiné
SN Satin nickel | ④ Cuivre satiné
SC Satin copper | ⑨ Bronze, sur demande
BZ Bronze, upon request |
| ⑤ Laiton poli
PB Polished brass | ⑥ Graphite poli
PG Polished graphite | ⑦ Nickel poli
PN Polished nickel | ⑧ Cuivre poli
PC Polished copper | |

ABAT-JOURS - LAMPSHADES



Drop Paper® 100 Drop Paper® 101 Chinette blanche
White chinette Chinette noire
Black chinette

CÂBLES - CABLES

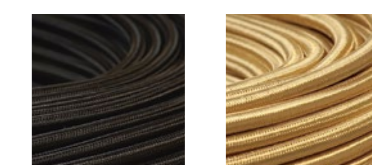

Tissu noir
Black textile Tissu or
Gold textile

VERRERIE - GLASS

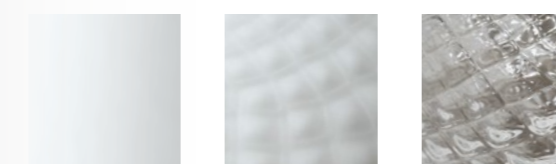

Opale
Opal Opale et écaille
Opal and patterned Claire et écaille
Clear and patterned

AUTRES - OTHERS

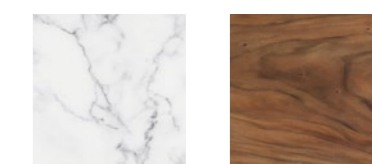

Marbre
Marble Noyer
Walnut

Charte graphique – Brand identity

POOL

Réalisation, suivi de fabrication

Layout, print process supervision

deuxpointdeux

Impression – Printing

DBS Print France

Images

Portraits

Atelier Grand Angle (É. Cathelineau), Stephanie Füssenich (P. Deltour), Yannick Labrousse (POOL), droits réservés/all rights reserved (H. Langlais), Nicolas Delaroche (S. Willenz)

Atelier, détails et groupe – Workshop, details and staff

Yannick Labrousse (p.2-11, 14, 60-61, 132, 205, 209,211, 215, 225, 227, 234-237, 239)

Photos & 3D d'ambiances – Lifestyle photos & 3Ds

Garnier Studios, except:

3mille for Kelly Boukobza – villa Saint-Tropez (p.22)

Agathe Tissier for Agence Felicita & Studio Vertbois (p.48, 109, 139)

Alexander Volodin & Ivan Erofeev for Arch(e)type – Supplier GK Concept (p.133)

Andres Orozco for Xuhui Zhang, Andy Chu, Limeng Jiang & Fran Fang – Junzi Kitchen Bleecker Street (p.155)

AR visual (p.105, 206, 210, 212, 214, 216, 224, 232)

Ariane Hera for Lelievre Paris (p.49)

Bureau Gimbert Comy architecture & design (p.51)

Bureau Slovo – Andrei Kabanov (p.156)

CGI Furniture (p.18 ,32, 39, 44, 62, 64, 65, 66, 68, 96, 98, 119, 121, 140, 144 ,146, 148, 178, 182-183, 186-187, 228)

Claire Illi for DH Liberty – Hampstead Manor (p.172)

Delphine Warin (p.218)

Francis Amiand for Stéphanie Coutas architecte d'intérieur (p.27)

Frédéric Namur Architecte d'intérieur (p.177)

Frenchie Cristogatin for agence Jean-Christophe Peyrieux; stylist: Céline Hassen (p.125)

Gname architecture studio (p.56)

Iqosa Interior and Architecture Design est. 2014 (p.155)

Klaas Verdrum for Mayelle architecture d'intérieur (p.152, 160)

Laura Evrat Photographe (p.20-21, 25, 80, 109, 117, 120, 146-147, 159, 165, 198, 203)

Leatzia Bazzoni for Marie's Corner (p.31)

Match Architects (p.92)

Mathias Paltrie for agence Contrast Deco (p.40)

Maud Lorton for Marir Birling – Le Répertoire (p.134)

Mikołaj Walczewski for Bernatowicz Architektura – Beauty for You, Hair Clinic Krakow (p.122)

Morgane Legall pour Lelièvre Paris (p.48)

Philippe Charlot (p.100, 192)

Pro Design St-Petersburg (p.220, 223)

Raffles Europejski Warsaw (p.168)

Rainer Schär for Iria Degen – Hotel Märthof Basel (p.73, 89)

Stephan Julliard for Studio Lally & Berger – Hôtel Le Meurice à Paris (p.53)

Yannick Labrousse for Studio AC – Adenauer (p.29)

Yannick Labrousse for POOL studio – project R0F01, Paris (p.47, 54, 59)

Mikołaj Walczewski for Bernatowicz Architektura Team – Zakopan Railway Station (p.126-127)

